

PCE-40, PCE-40 1040162330
PCE-60, PCE-60 1040162530

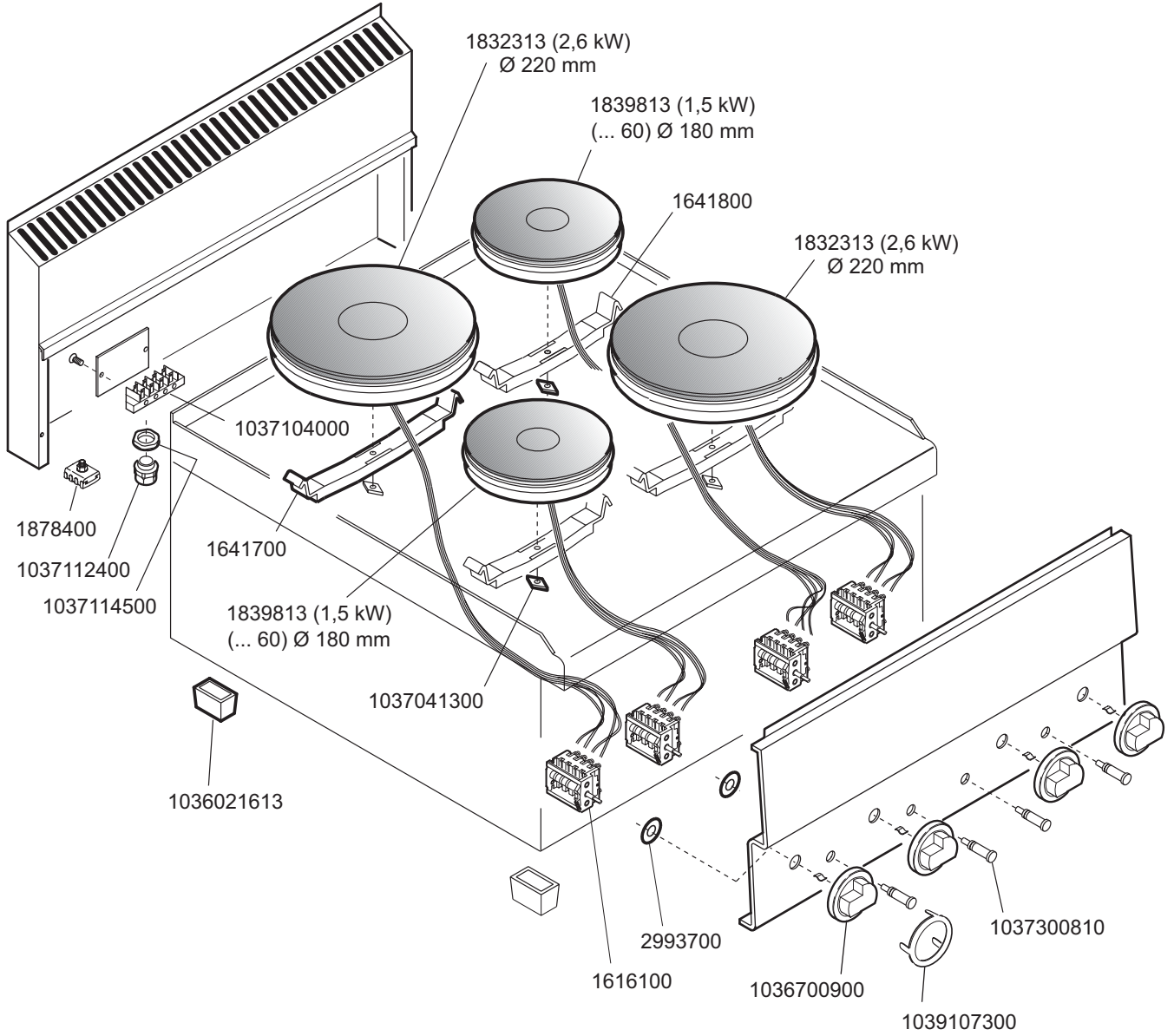

PIANI DI COTTURA ELETTRICI
ELECTRIC HEATED COOKING TOP
PLANS DE CUISSON ELECTRIQUES
ELEKTRISCHE KOCHSTELLEN

PCE-40D 1040240214
PCE-40DB 1040240314
PCE-60D 1040240414
PCE-60DB 1040240514



1036701200
MA,



 MARENO INDUSTRIES ALI spa Mareno di Piave (TV)	ELABORATO:	APPROVATO:	GRUPPO:	DENOMINAZIONE:		
	G.Z.		Serie 600 Snack	Impianto elettrico - Mobile		
	DATA:	DATA:	PARTICOLARE:	REV. N.	DEL	DISEGNO N.
	10 Ott 1996	10 Ott 1996	Disegno esploso per ricambi	Z01	0106	3.6.38.PCE
SOST. DIS.	Z00.9610.3.6.38.PCE					

PCVE-40 1040197810
 PCVE-60 1040197910

PCVE-40D 1040240614
 PCVE-40DB 1040240714
 PCVE-60D 1040240814
 PCVE-60DB 1040240914

PIANI DI COTTURA VETROCERAMICA
 GLASS CERAMIC COOKING TOP
 PLANS DE CUISSON AVEC PLAQUE VITROCERAMIQUE
 GERAN-KOCHFLÄCHEN KOCHSTELLEN

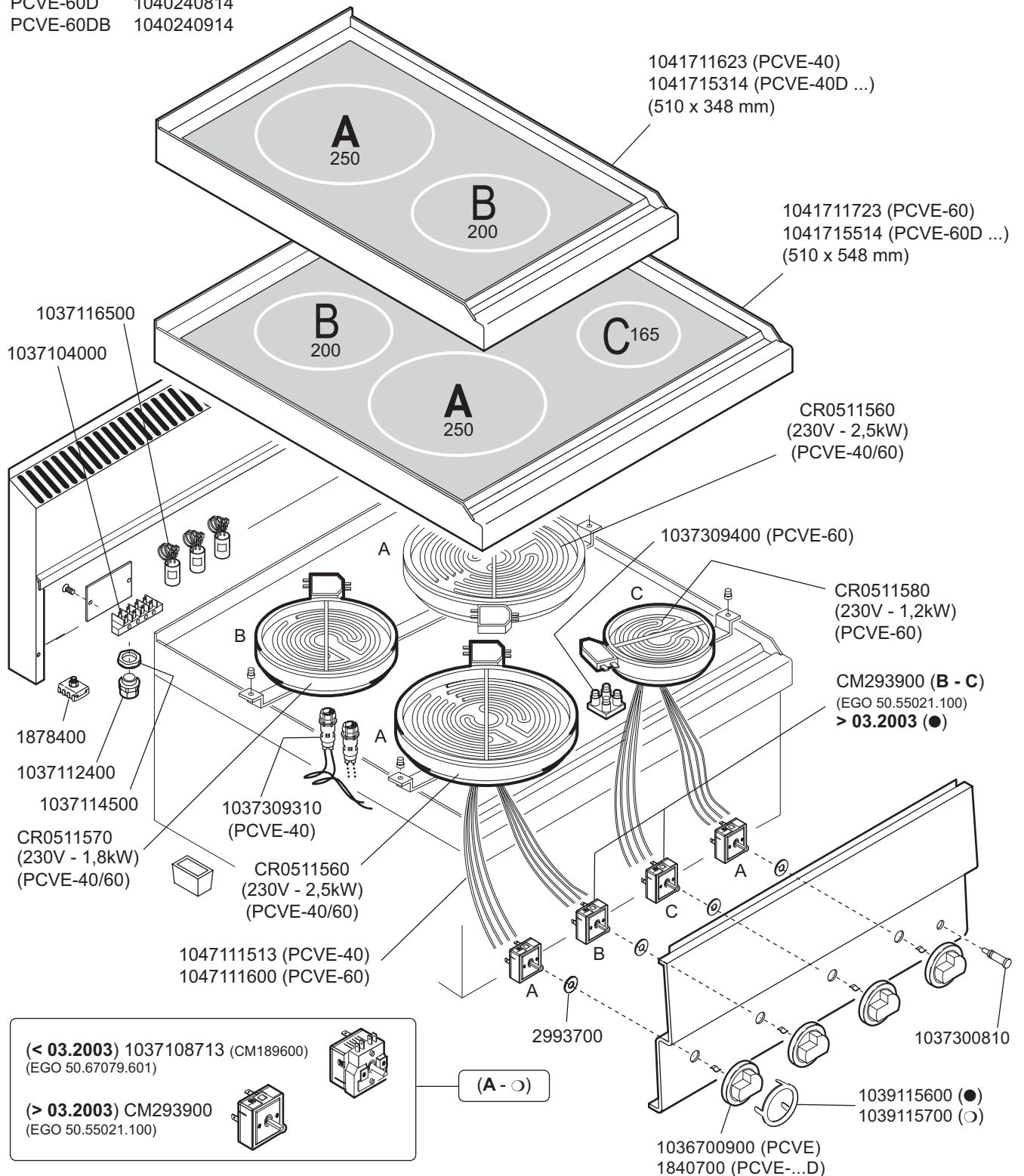

(< 03.2003) 1037108713 (CM189600) (EGO 50.67079.601)

(> 03.2003) CM293900 (EGO 50.55021.100)

(●) 1 Settore - 1 Field - 1 Zone - 1 Feld (○) 2 Settori - 2 Fields - 2 Zones - 2 Felder



1036706400 (●)
 1036706500 (○)
 MA,



<p>MARENO INDUSTRIE ALI spa Mareno di Piave (TV)</p>	ELABORATO:	APPROVATO:	GRUPPO:	DENOMINAZIONE:		
	G.Z.		Serie 600 Snack	Impianto elettrico - Mobile		
	DATA:	DATA:	PARTICOLARE:	REV. N.	DEL	DISEGNO N.
	10 Ott 1996	10 Ott 1996	Disegno esploso per ricambi	Z05	1208	3.6.39
SOST. DIS.	Z04.0706.3.6.39					

CUCINE ELETTRICHE
ELECTRIC HEATED RANGES
CUISINIÈRES ELECTRIQUES
ELEKTROBEHEIZTE HERDE

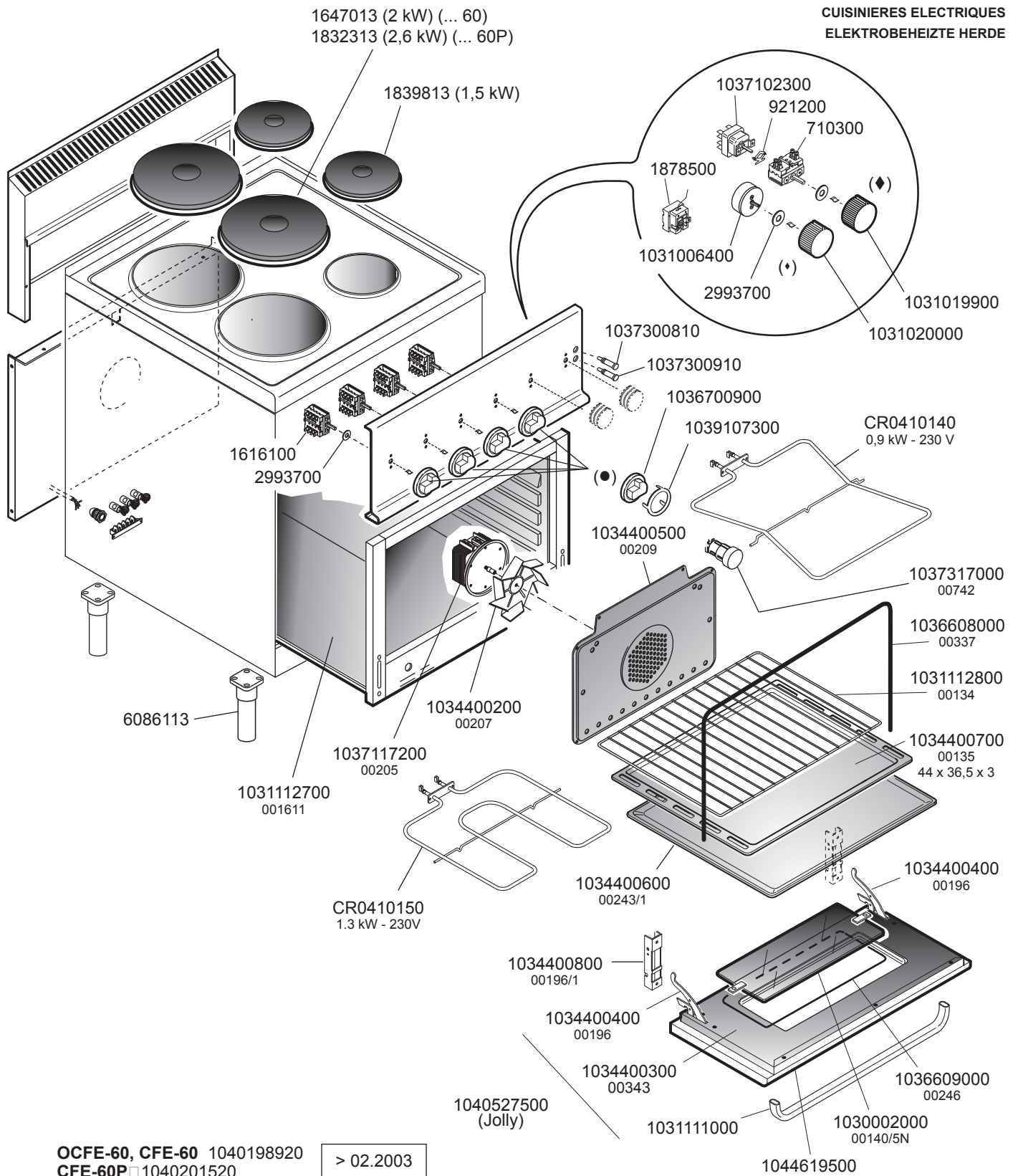

OCFE-60, CFE-60 1040198920
CFE-60P 1040201520

> 02.2003



◆ Contaminuti - Timer -

◆ Termostato - Thermostat



1036701200
MA



 MARENO INDUSTRIE ALI spa Mareno di Piave (TV)	ELABORATO:	APPROVATO:	GRUPPO:	DENOMINAZIONE:		
	G.Z.		Serie 600 Snack - Jolly	Impianto elettrico - Mobile		
	DATA:	DATA:	PARTICOLARE:	REV. N.	DEL	DISEGNO N.
	20 Mar 2000	20 Mar 2000	Disegno esploso per ricambi	Z03	0106	3.6.27/60
SOST. DIS. Z02.0802.3.6.27/60						

CUCINE VETROCERAMICA
CERAN HOBS RANGES

CUISINIÈRES AVEC PLAQUE VITROCERAMIQUE
CERAN-KOCHFLÄCHEN HERDE

Mod. CFVE-60
1040200010

☞ 02.2003

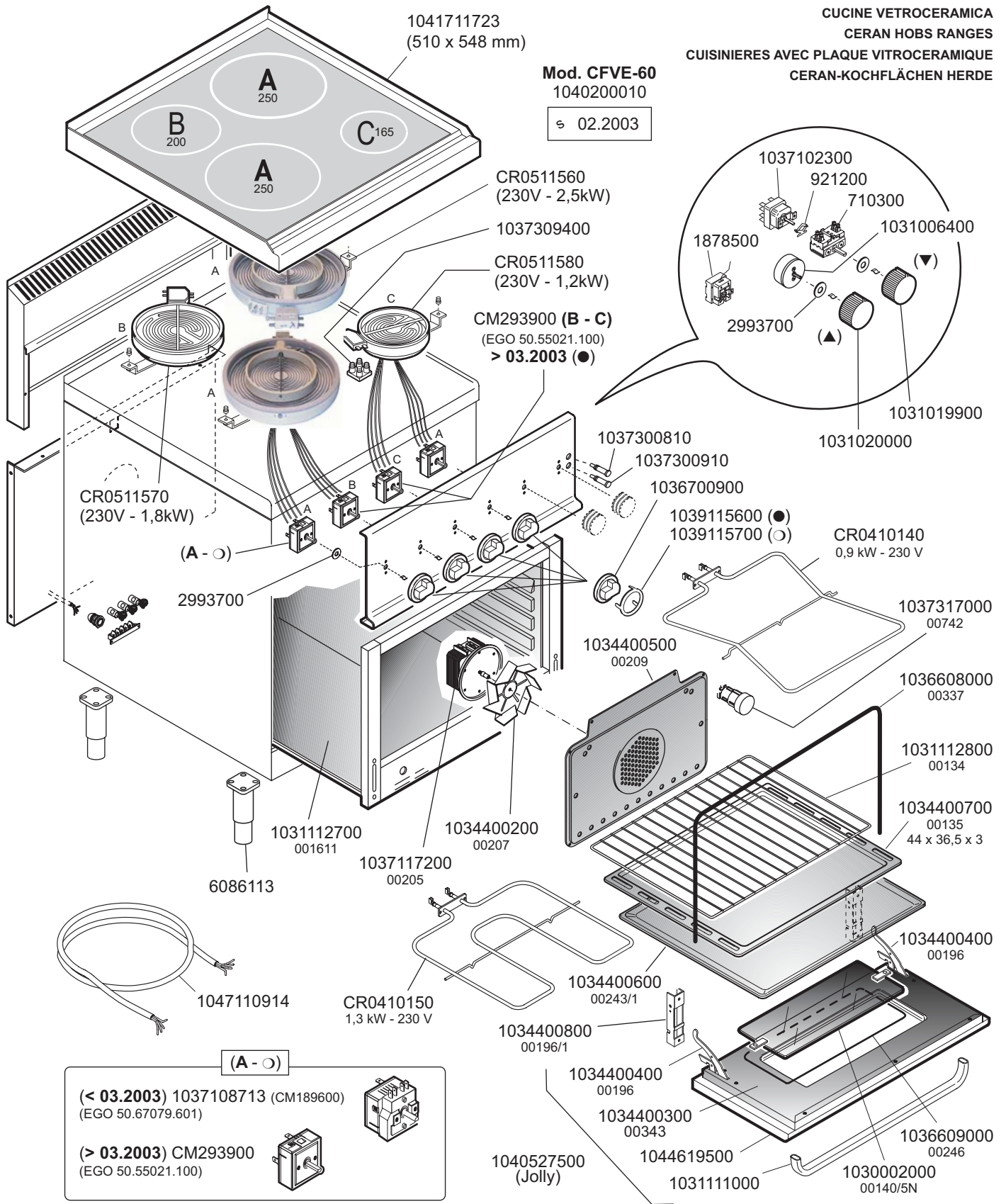

(A - ○)

(< 03.2003) 1037108713 (CM189600) (EGO 50.67079.601)

(> 03.2003) CM293900 (EGO 50.55021.100)

(▲) Contaminuti - Timer (▼) Termostato - Thermostat (●) 1 Settore - 1 Field - 1 Zone - 1 Feld (○) 2 Settori - 2 Fields - 2 Zones - 2 Felder



<p>MARENO INDUSTRIE ALI spa Mareno di Piave (TV)</p>	ELABORATO:	APPROVATO:	GRUPPO:	DENOMINAZIONE:		
	G.Z.		Serie 600 Snack - Jolly	Impianto elettrico - Mobile		
	DATA:	DATA:	PARTICOLARE:	REV. N.	DEL	DISEGNO N.
	20 Mar 2000	20 Mar 2000	Disegno esploso per ricambi	▼ Z06	▼ 1208	▼ 3.6.43
SOST. DIS.	Z05.0706.3.6.43		CE			

CUCINE ELETTRICHE
ELECTRIC HEATED RANGES
CUSINIÈRES ELECTRIQUES
ELEKTROBEHEIZTE HERDE

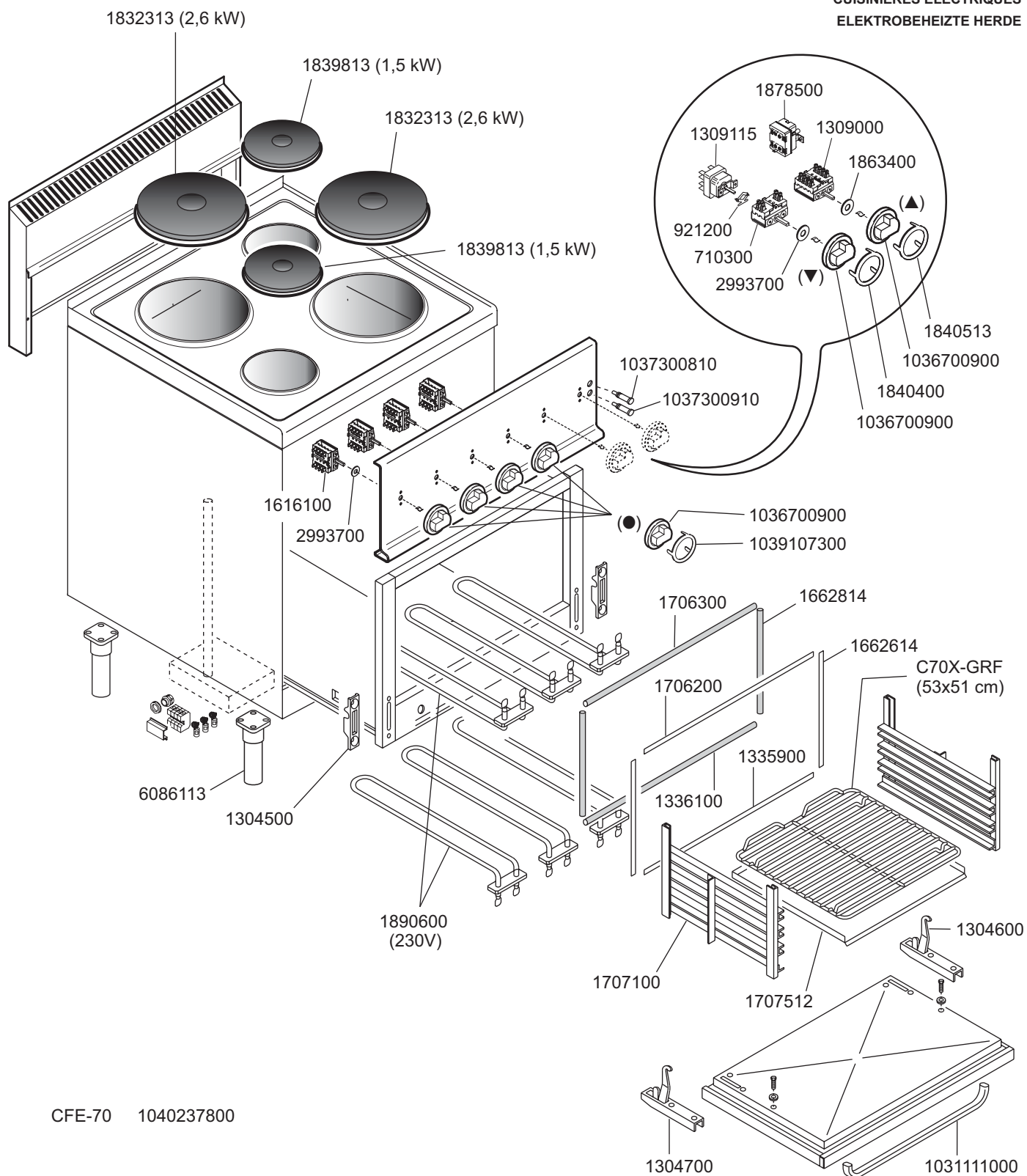

CFE-70 1040237800

▲ Selettore - Change over switch - Commutateur - Umschalter ▼ Termostato - Thermostat

			1036701200 MA, (●) 1036713100 MA, (▲) 1036701314 MA, (▼)		
ELABORATO:	APPROVATO:	GRUPPO:	DENOMINAZIONE:		
G.Z.		Serie 600 Snack	Impianto elettrico - Mobile		
DATA:	DATA:	PARTICOLARE:	REV. N.	DEL	DISEGNO N.
20 Mar 2000	20 Mar 2000	Disegno esploso per ricambi	▼	▼	▼
SOST. DIS.	Z01.0101.3.6.27.CFE		Z02	0203	3.6.27.CFE

FTE-40B 1040162730
 FTE-40BR 1040238200
 FTE-60B 1040162830
 FTE-60BR 1040163030

FTE-40C 1040193520
 FTE-60C 1040163220
 FTE-100CRL 1040201610
 FTE-100C 1040102490
 FTE-100B 1040162930
 FTE-100BR 1040163130

FTE-40D (B) 1040241114
 FTE-60D (B) 1040241314
 FTE-60DR (B) 1040241514

FTE-40DC (B) 1040242114
 FTE-60DC (B) 1040242314
 FTE-60DCRL (B) 1040242514

FRY TOPS E BISTECCHIERE ELETTRICI
ELECTRIC HEATED FRY TOPS
GRILLES ELECTRIQUES
**ELEKTROBEHEIZTE BRAT-
 UND GRILLPLATTEN**

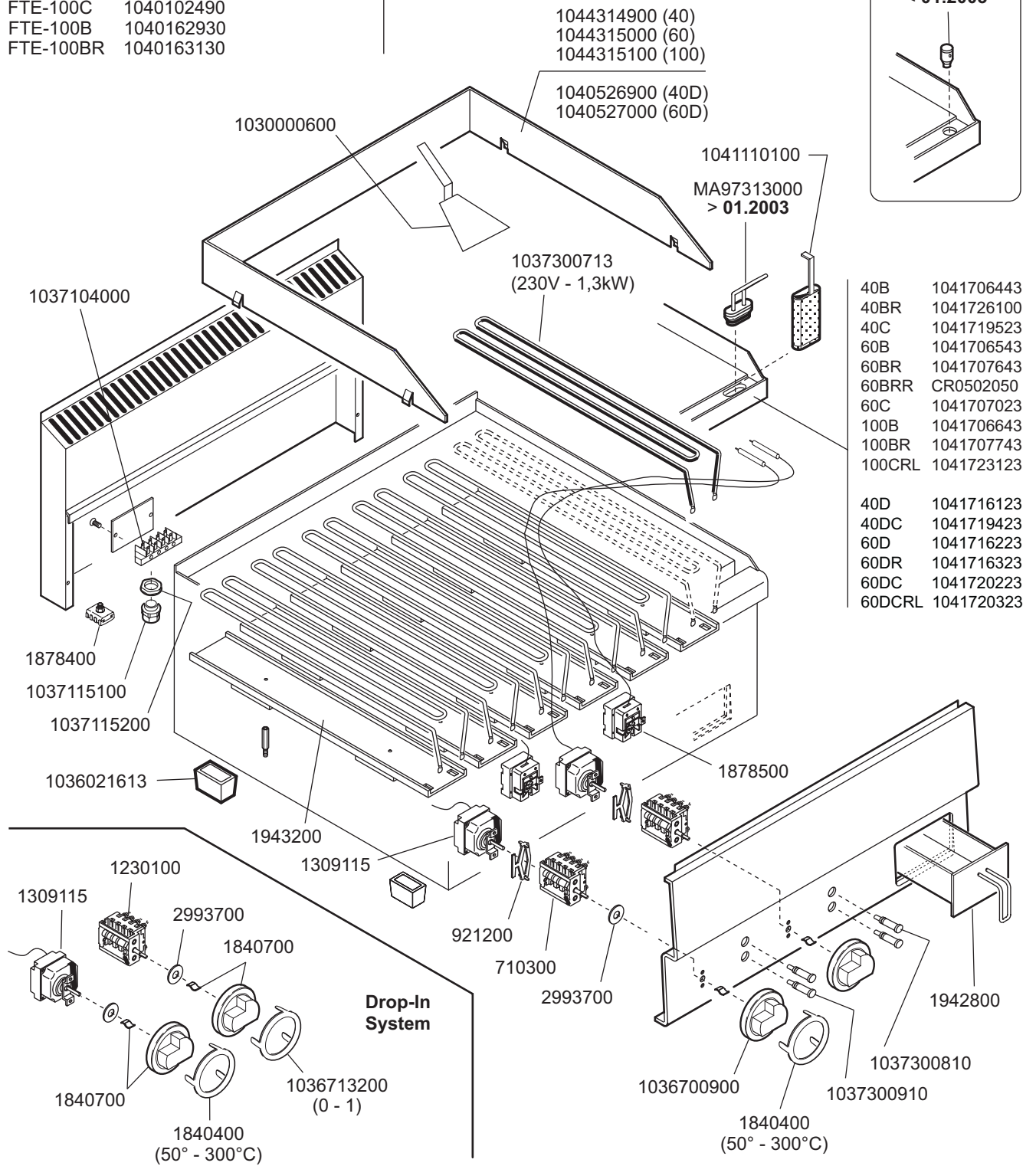
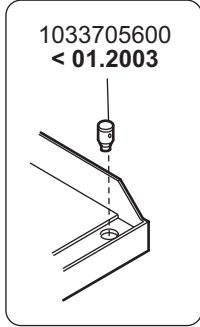

- 40B 1041706443
- 40BR 1041726100
- 40C 1041719523
- 60B 1041706543
- 60BR 1041707643
- 60BRR CR0502050
- 60C 1041707023
- 100B 1041706643
- 100BR 1041707743
- 100CRL 1041723123

- 40D 1041716123
- 40DC 1041719423
- 60D 1041716223
- 60DR 1041716323
- 60DC 1041720223
- 60DCRL 1041720323



1036701314
 MA

 MARENO INDUSTRIE ALI spa Mareno di Piave (TV)	ELABORATO:	APPROVATO:	GRUPPO:	DENOMINAZIONE:		
	G.Z.		Serie 600 Snack	Impianto elettrico - Mobile		
	DATA:	DATA:	PARTICOLARE:	REV. N.	DEL	DISEGNO N.
	10 Dic 1996	10 Dic 1996	Disegno esploso per ricambi	Z02	1006	3.6.46
SOST. DIS.	Z02.0406.3.6.46		CE			

BIE-40B 1040164730
BIE-60B 1040166130

BISTECCHIERE ELETTRICHE
ELECTRIC HEATED GRILLES
GRILLES ELECTRIQUES
ELEKTROBEHEIZTE GRILLPLATTEN

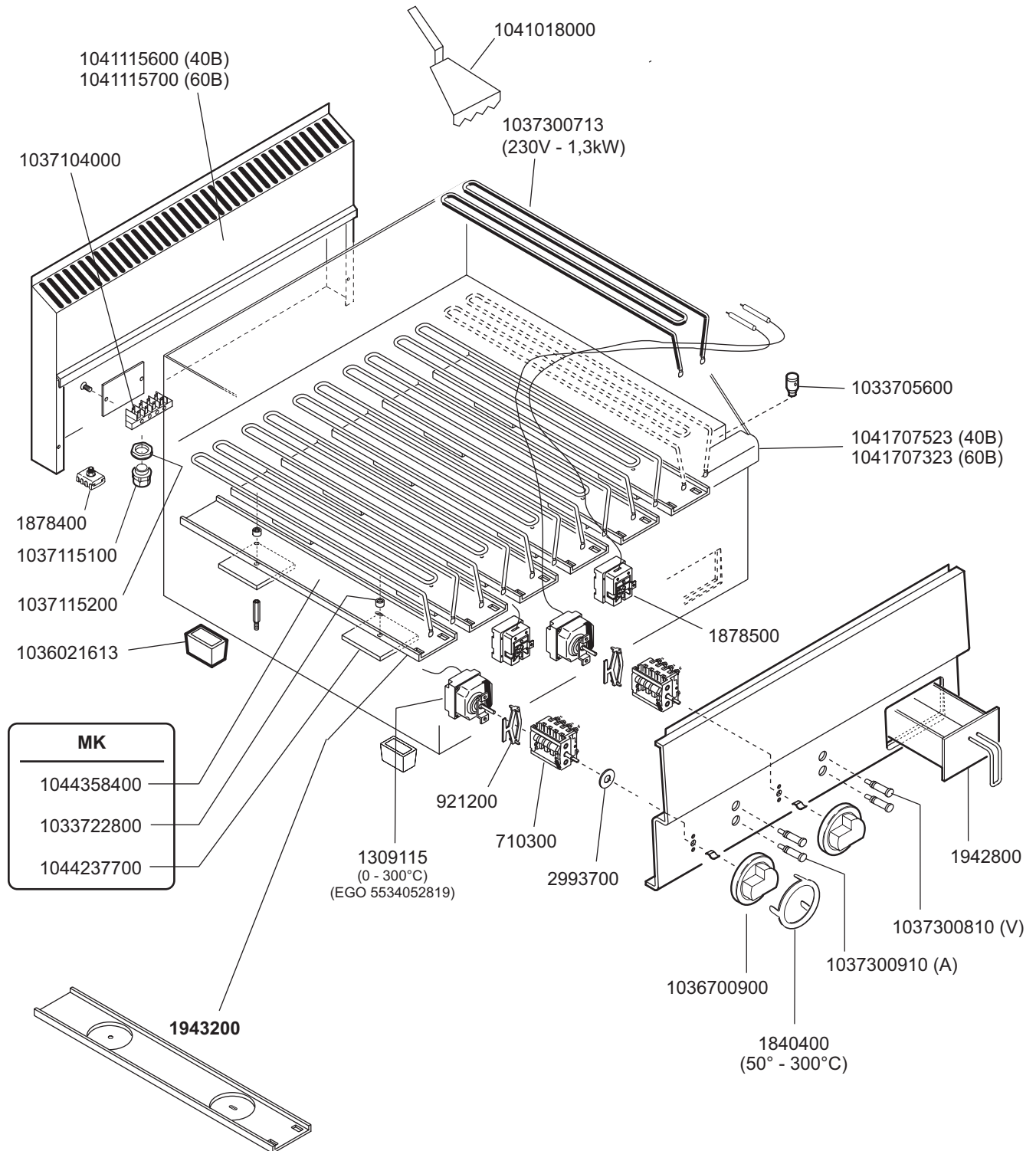

1036701314
 MA



<p>MARENO INDUSTRIE ALI spa Mareno di Piave (TV)</p>	ELABORATO:	APPROVATO:	GRUPPO:	DENOMINAZIONE:		
			Serie 600 Snack	Impianto elettrico - Mobile		
	DATA:	DATA:	PARTICOLARE:	REV. N.	DEL	DISEGNO N.
	10 Set 1996	10 Set 1996	Disegno esploso per ricambi	▼	▼	▼
SOST. DIS.	P00.9609.3.6.32.BIE			Z01	0407	3.6.32

BRE-40 □ 1040163320 (OBRE-40)
 BRE-40G □ 1040163420

BRE-40D □ 1040242614
 BRE-40DB □ 1040242714
 BRE-40DG □ 1040242814
 BRE-40DGB 1040242914

BRASIERE ELETTRICHE
ELECTRIC HEATED BRATT PANS
SAUTEUSES ELECTRIQUES
ELEKTROBEHEIZTE SUDWANNEN

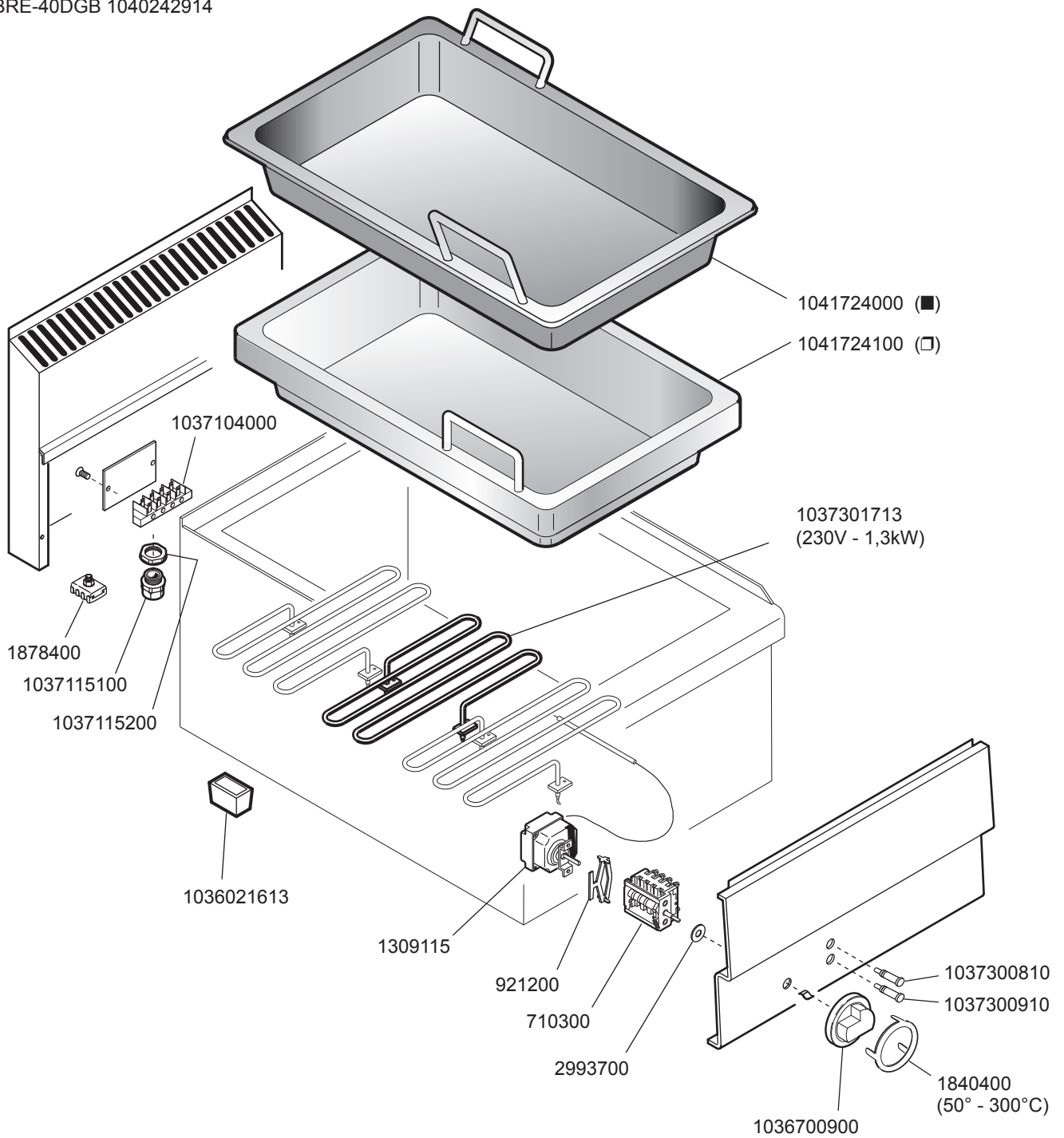

□ (AISI 304) Acciaio Inox - Stainless Steel - Acier Inox - Chromnickelstahl

■ Ghisa - Cast iron - Fonte - Gußeisen



1036701314
 MA



 MARENO INDUSTRIES ALI spa Mareno di Piave (TV)	ELABORATO:	APPROVATO:	GRUPPO:	DENOMINAZIONE:		
	G.Z.		Serie 600 Snack	Impianto elettrico - Mobile		
	DATA:	DATA:	PARTICOLARE:	REV. N.	DEL	DISEGNO N.
	10 Gen 1997	10 Gen 1997	Disegno esploso per ricambi	Z01	0106	3.6.45
SOST. DIS.	Z00.9701.3.6.45.BRE		CE			

CUOCIWÜRSTEL ELETTRICI
ELECTRIC-HEATED SAUSAGE GRILL
GRILLES ELECTRIQUES
ELEKTROBEHEIZTE ROSTBRÄTER

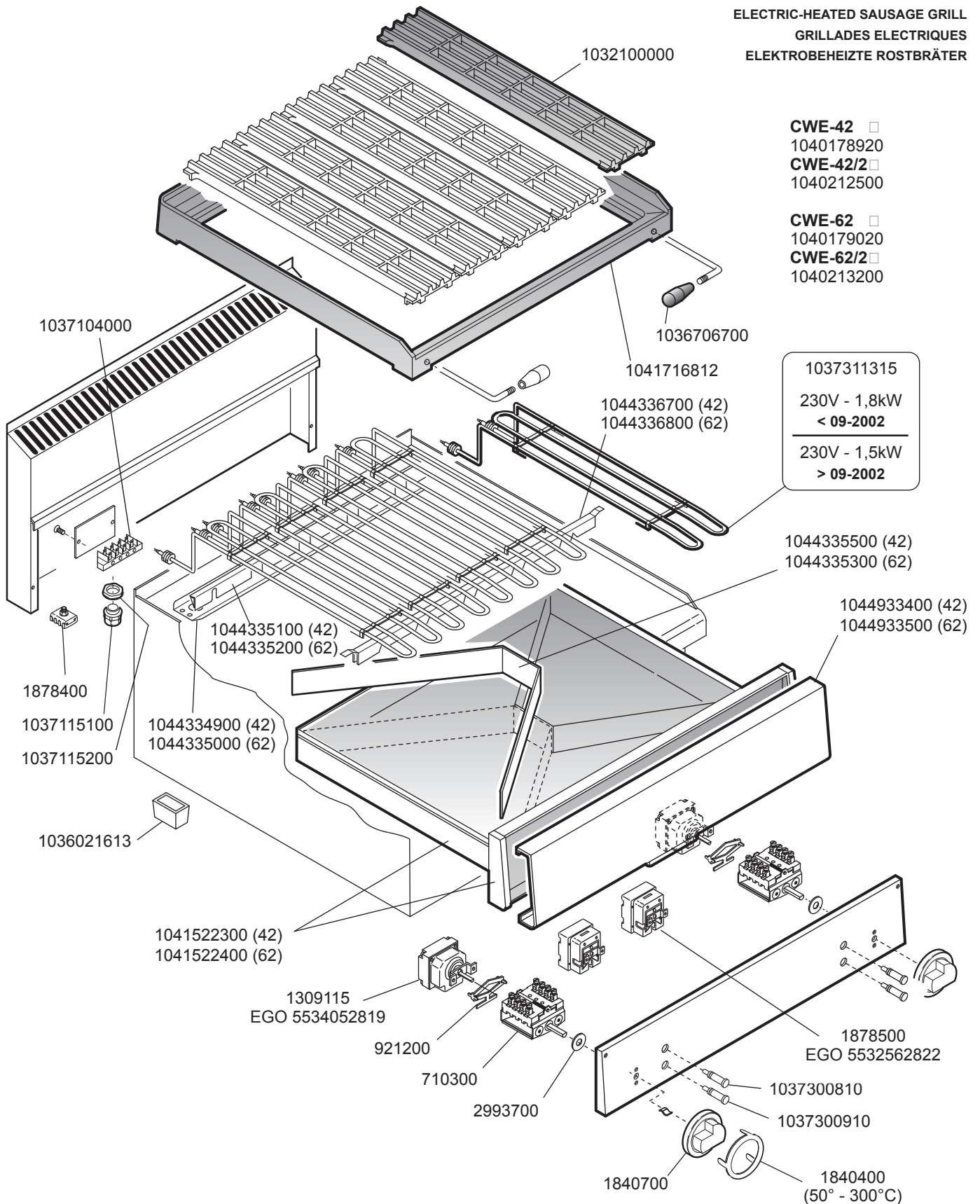

1036703014
MA

 MARENO INDUSTRIE ALI spa Mareno di Piave (TV)	ELABORATO:	APPROVATO:	GRUPPO:	DENOMINAZIONE:		
	G.Z.		Serie 600 Snack	Impianto elettrico - Mobile		
	DATA:	DATA:	PARTICOLARE:	REV. N.	DEL	DISEGNO N.
	10 Gen 1997	10 Gen 1997	Disegno esploso per ricambi	Z03	0106	3.6.44
SOST. DIS.	Z02.0106.3.6.44.CWE		CE			

RISCALDATORI ELETTRICI
 HIGH OUTPUT UNITS ELECTRIC HEATED
 APPAREILS CHAUFFANT ELECTRIQUES
 WÄRMEABSTRAHLER ELEKTROBEHEIZTE

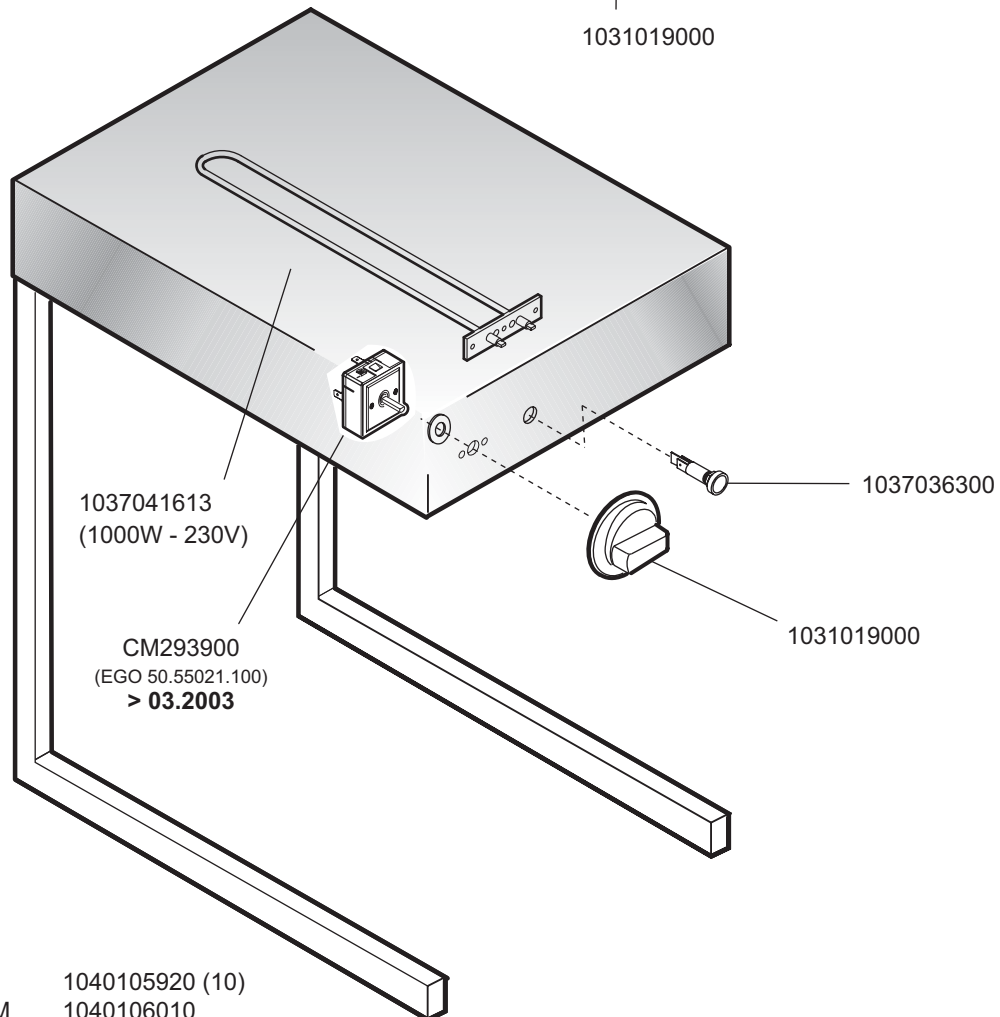
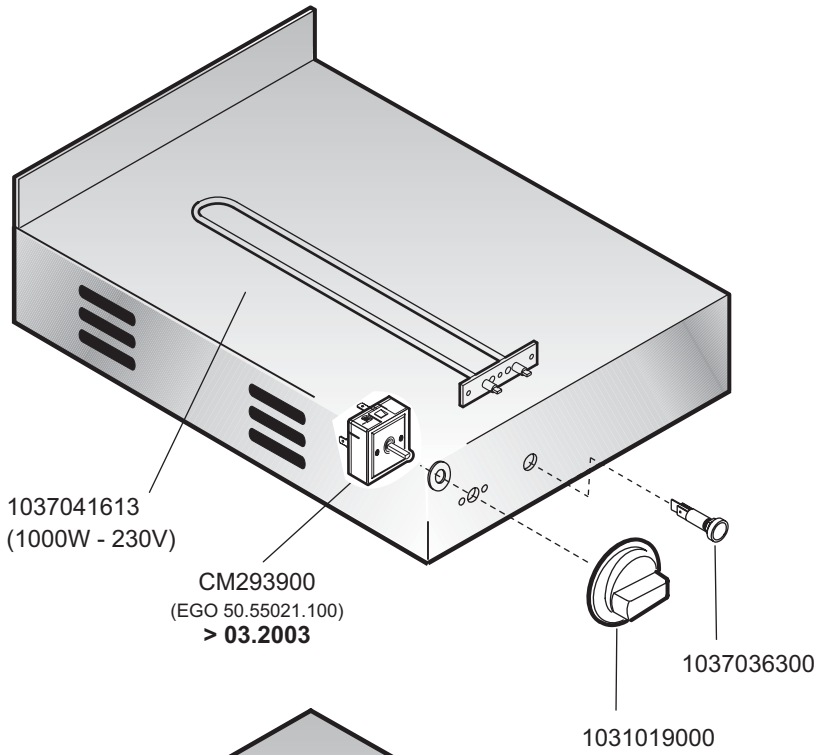

RIE-40M 1040105920 (10)
 RIEP-40M 1040106010

ELABORATO:	APPROVATO:	GRUPPO:	DENOMINAZIONE:		
G.Z.		Serie 600 Snack	Impianto elettrico - Mobile		
DATA:	DATA:	PARTICOLARE:	REV. N.	DEL	DISEGNO N.
10 Giu 1997	10 Giu 1997	Disegno esploso per ricambi	▼	▼	▼
SOST. DIS.	Z01.0105.3.6.48.RIE		Z02	0803	3.6.48



BSEI-40M

1040238800

CONTENITORE RISCALDATO A SECCO (SCALDAPATATE)

HOT FOOD CONTAINER

BAIN MARIE A AIR CHAUDE

ELEKTRO-TROCKENBEHEIZT BAIN MARIE

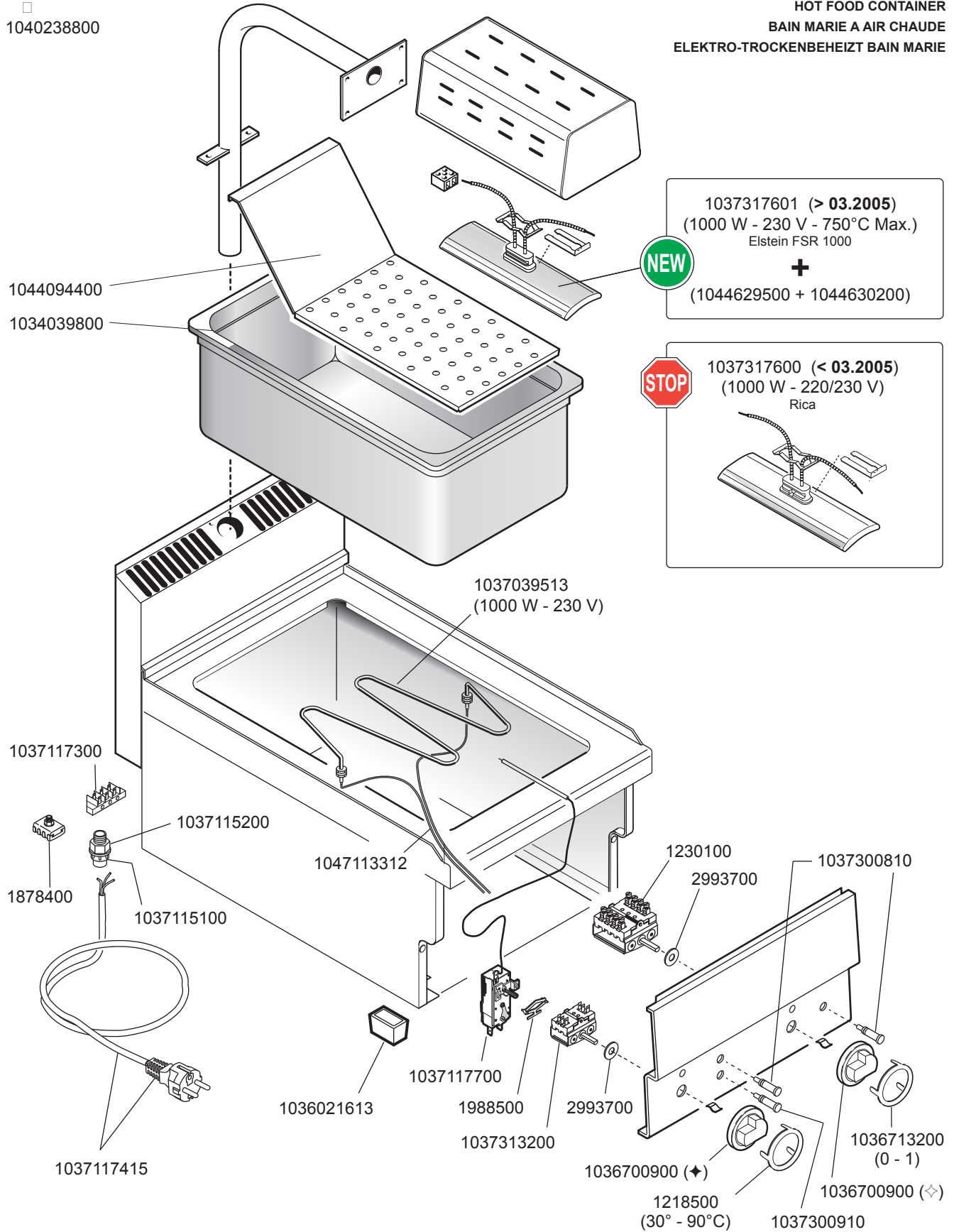

1036701113 (↔) MA
1036713300 (↔)

 MARENO INDUSTRIE ALI spa Mareno di Piave (TV)	ELABORATO:	APPROVATO:	GRUPPO:	DENOMINAZIONE:		
	G.Z.		Serie 600 Snack	Impianto elettrico - Mobile		
	DATA:	DATA:	PARTICOLARE:	REV. N.	DEL	DISEGNO N.
	20 Mar 2000	20 Mar 2000	Disegno esploso per ricambi	▼	▼	▼
SOST. DIS.	Z00.0101.3.6.56.BSE			Z01	0106	3.6.56

BME-40M 1040163630
 BME-60M 1040163730
 BME-80M 1040163930

BME-40DM 1040243400
 BME-40DMB 1040243500
 BME-60DM 1040243600
 BME-60DMB 1040243700

10.440.945-23 (BME-40)
 10.440.946-23 (BME-60)
 10.440.947-23 (BME-80)

BAGNOMARIA ELETTRICI
 ELECTRIC HEATED BAIMARIE
 BAIN MARIE ELECTRIQUES
 ELEKTROBEHEIZTE WASSERBÄDER

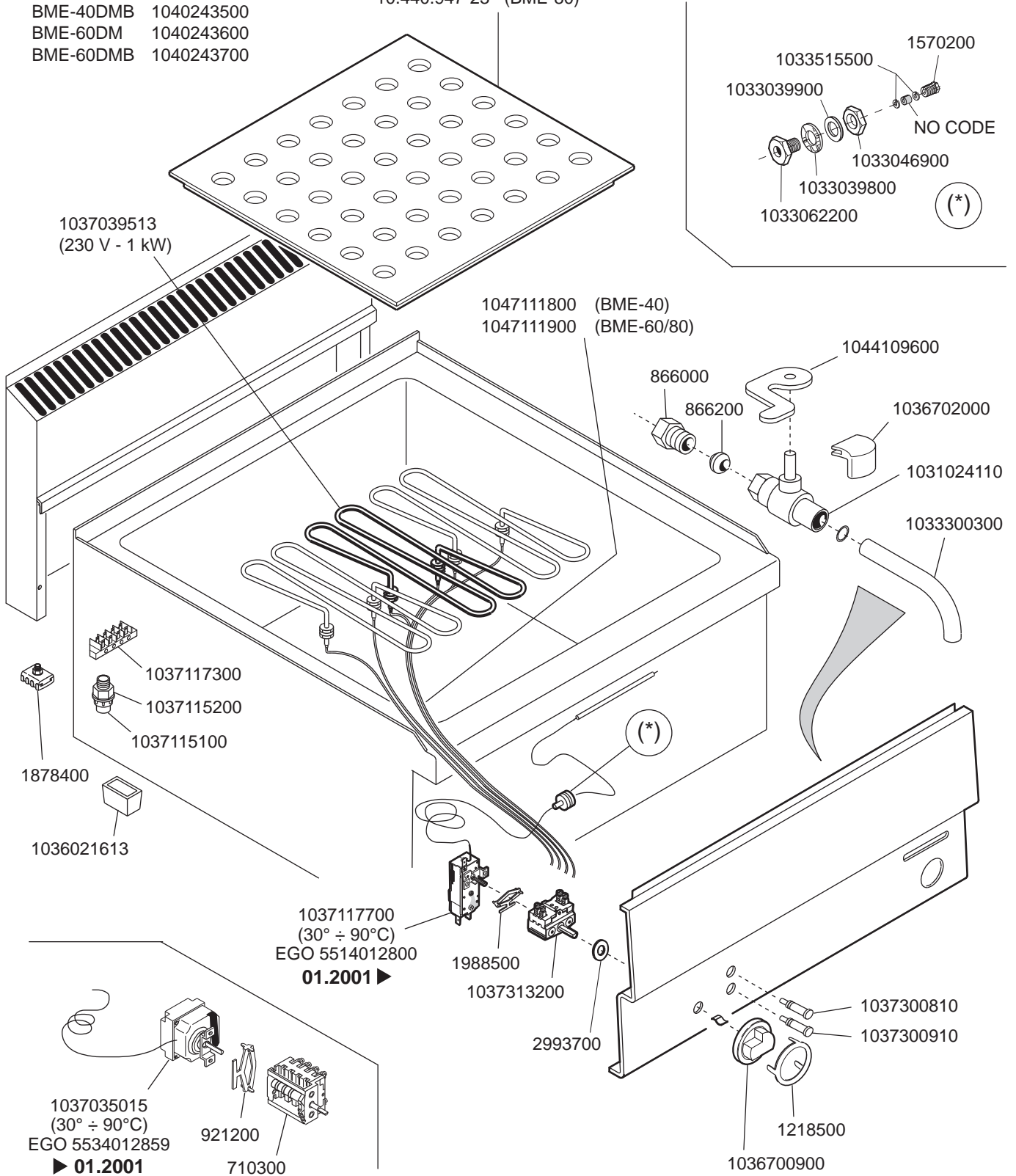

1036701113
 MA



	ELABORATO: G.Z.	APPROVATO:	GRUPPO: Serie 600 Snack	DENOMINAZIONE: Impianto elettrico - Mobile		
	DATA: 10 Ott 1996	DATA: 10 Ott 1996	PARTICOLARE: Disegno esploso per ricambi	REV. N. Z02	DEL 0602	DISEGNO N. 3.6.37
	SOST. DIS. Z01.0101.3.6.37.BME		CE			

CUOCIPASTA ELETTRICI
ELECTRIC HEATED PASTA-COOKER
CUISEUR A PATES ELECTRIQUES
ELEKTROBEHEIZTE TEIGWARENKOCHER

Mod.

CPE-60
 1040164020

CPE-60DB
 1040182900

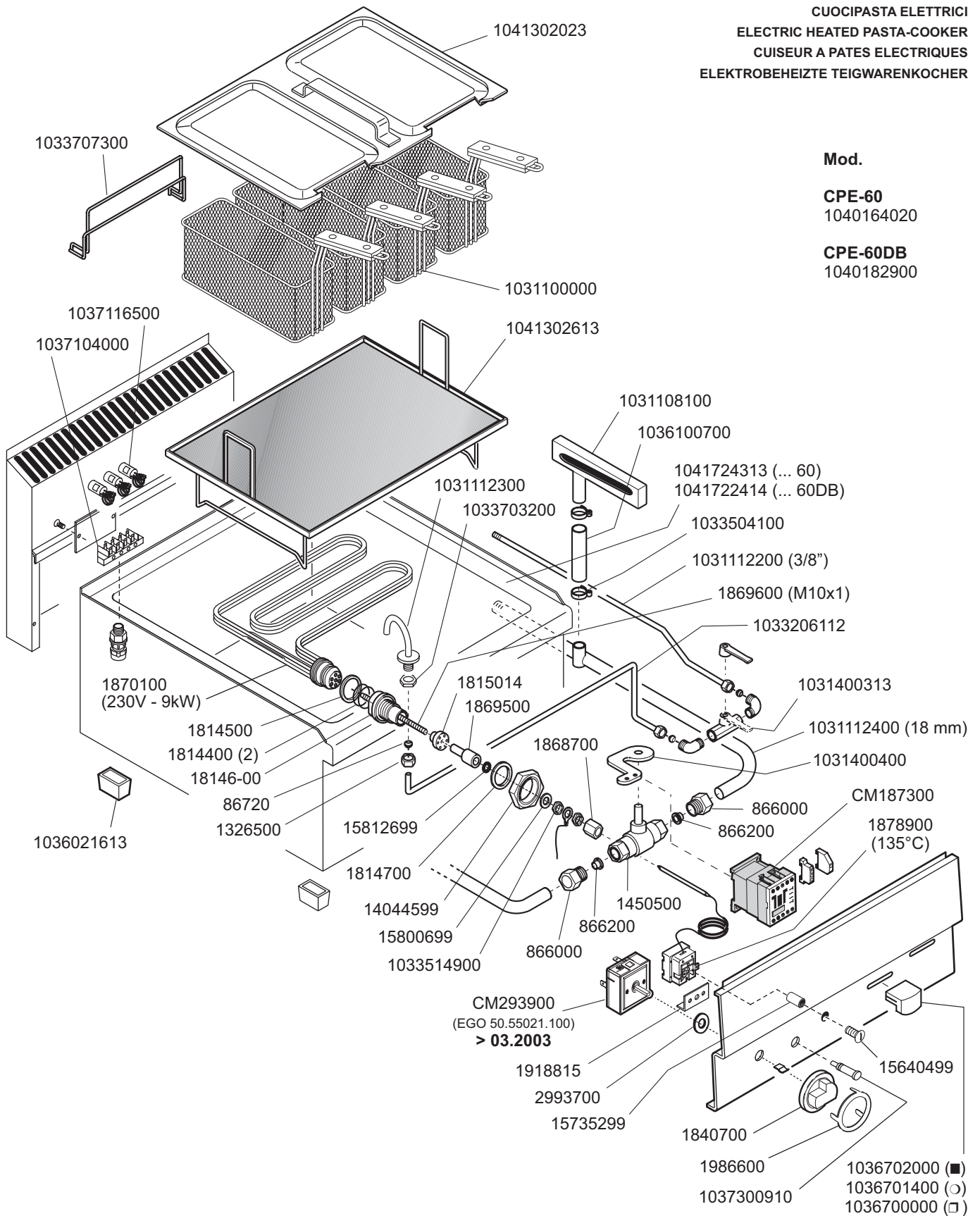

□ Verde - Green - Vert - Grün ■ Nero - Black - Noir - Schwarz ○ Rosso - Red - Rouge - Rot



1036703115
 MA





 MARENO INDUSTRIE ALI spa Mareno di Piave (TV)	ELABORATO:	APPROVATO:	GRUPPO:	DENOMINAZIONE:		
	G.Z.		Serie 600 Snack	Impianto elettrico - Mobile		
	DATA:	DATA:	PARTICOLARE:	REV. N.	DEL	DISEGNO N.
	10 Nov 1996	10 Nov 1996	Disegno esploso per ricambi	▼ Z03	▼ 0106	▼ 3.6.41
SOST. DIS.	Z02.0101.3.6.41.CPE		CE			

FQE-41, FQE 41 1040194130
 FQE 41L 1040194330
 FQE 41L2 1040200220

FQE-61, FQE 61 1040194240
 FQE 61L 1040194440
 FQE 61L2 1040200330

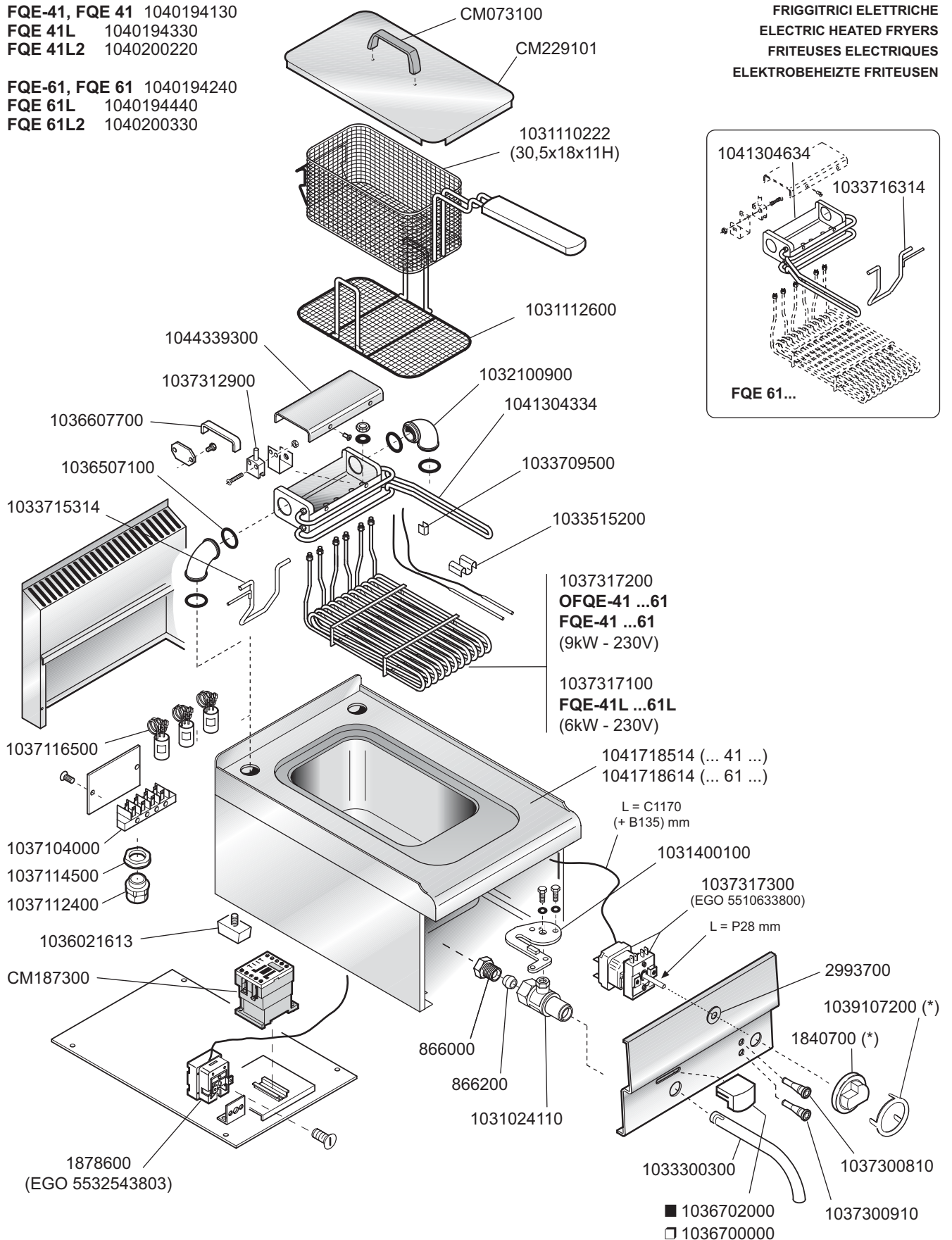
FRIGGITRICI ELETTRICHE
 ELECTRIC HEATED FRYERS
 FRITEUSES ELECTRIQUES
 ELEKTROBEHEIZTE FRITZESEN



 MARENO INDUSTRIE ALI spa Mareno di Piave (TV)	ELABORATO:	APPROVATO:	GRUPPO:	DENOMINAZIONE:		
			Serie 600 Snack	Impianto elettrico - Mobile		
	DATA:	DATA:	PARTICOLARE:	REV. N.	DEL	DISEGNO N.
	05 Dic 2000	05 Dic 2000	Disegno esploso per ricambi	▼	▼	▼
SOST. DIS.	Z01.9811.3.6.42.F41			Z02	0106	3.6.42.FQE

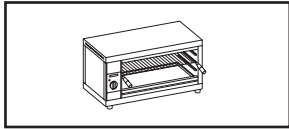

SALAMANDRE ELETTRICHE
ELECTRIC HEATED SALAMANDER GRILLS
SALAMANDRE ELECTRIQUES
ELEKTROBEHEIZTE SALAMANDER

SME-62M 1040105330
SME-63M 1040105430
SME-70M 1040105530

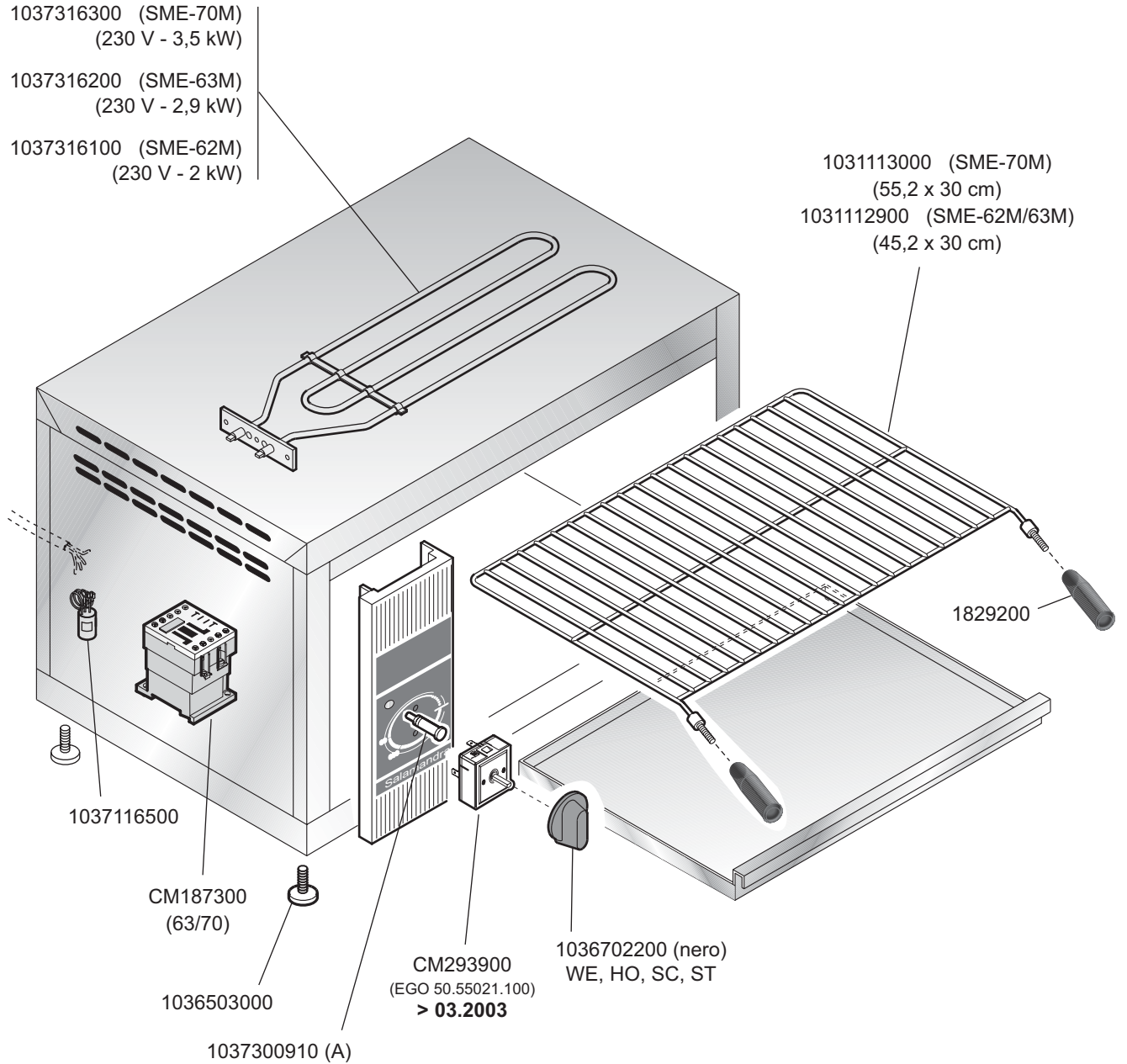

 MARENO INDUSTRIES ALI spa Mareno di Piave (TV)	ELABORATO:	APPROVATO:	GRUPPO:	DENOMINAZIONE:		
	G.Z.		Serie Snack	Impianto elettrico - Mobile		
	DATA:	DATA:	PARTICOLARE:	REV. N.	DEL	DISEGNO N.
	20 Mag 1999	20 Mag 1999	Disegno esploso per ricambi	▼ Z03	▼ 0803	▼ 3.6.51
SOST. DIS.	Z02.0105.3.6.51.SME					

PIANI DI COTTURA - FUOCHI APERTI A GAS
 COOKING TOPS - OPEN BURNERS GAS HEATED
 PLANS DE CUISSON - FEUX VIFS A GAZ
 KOCHSTELLEN GASBEHEIZTE

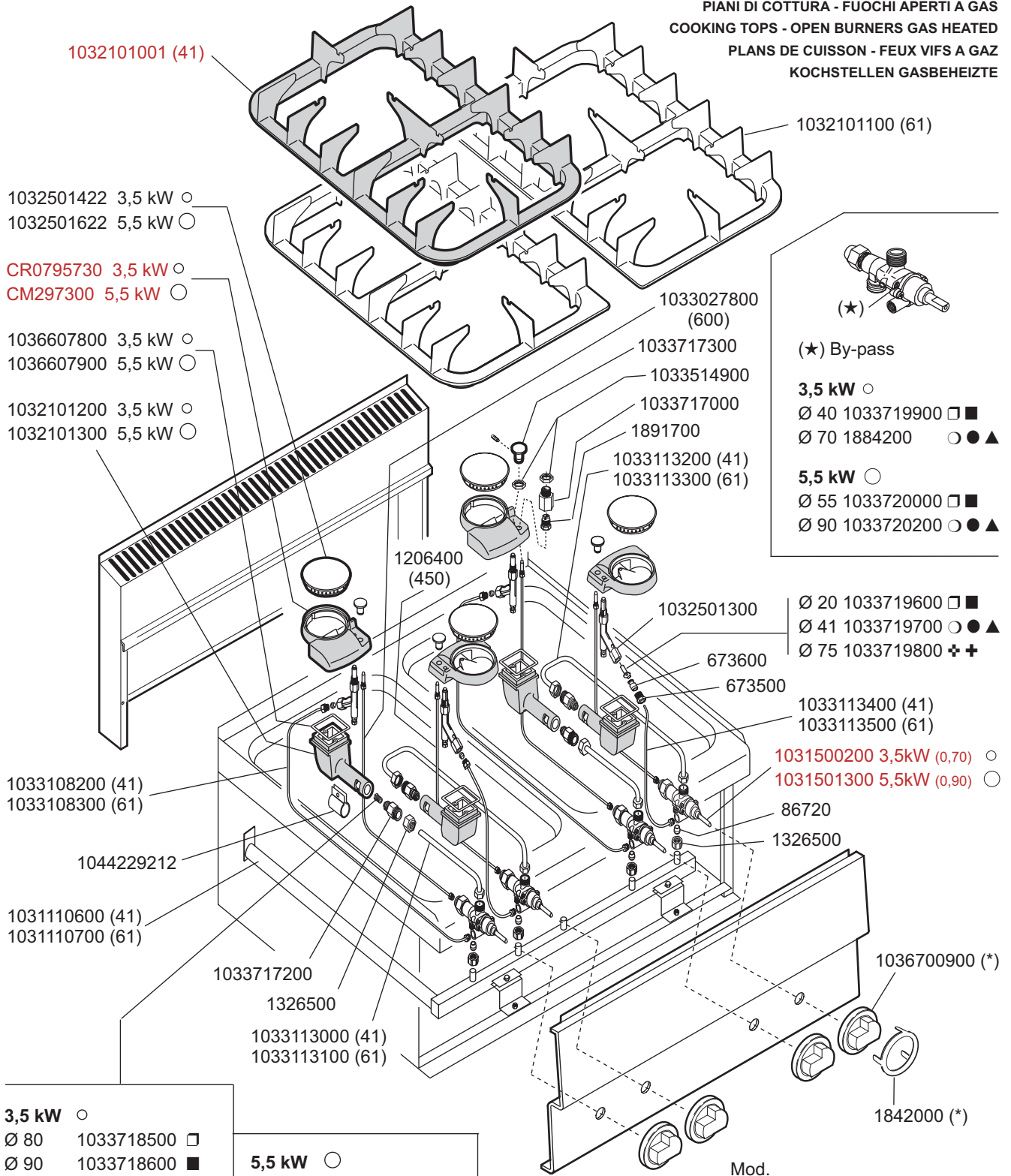

ID GAS: □ G30/50 ■ G30/29 ○ G20/20 ● G25/25 ▲ G25/20 ✚ G120/8 ✚ G110/8

<p>MARENO INDUSTRIE ALI spa Mareno di Piave (TV)</p>	ELABORATO:	APPROVATO:	GRUPPO:	DENOMINAZIONE:		
	G.Z.		Serie 600 Snack	Impianto gas - Mobile		
	DATA:	DATA:	PARTICOLARE:	REV. N.	DEL	DISEGNO N.
	10 Ott 1996	10 Ott 1996	Disegno esploso per ricambi	Z02	1010	3.6.02/03
SOST. DIS.	Z02.0106.3.6.02/03.PCG		CE			

CFGE-61 1040357910
 CFGE-61D 1040358000
 CFGE-61L 1040358110
 CFGE-61P 1040358200

CUCINE MISTE GAS - ELETTRICHE
 GAS AND ELECTRIC HEATED RANGES
 CUISINIÈRES MIXTES A GAZ ET ELECTRIQUES
 GAS UND ELEKTROBEHEIZTE HERDE

- 1032501422 3,5 kW ○
- 1032501622 5,5 kW ○
- 1032101400 3,5 kW ○
- 1032101500 5,5 kW ○
- 1036607800 3,5 kW ○
- 1036607900 5,5 kW ○
- 1032101200 3,5 kW ○
- 1032101300 5,5 kW ○

- | | | | |
|---------------------|----|---------------------|----|
| 3,5 kW ○ | ○ | 5,5 kW ○ | ○ |
| Ø 80 1033718500 □ | □ | Ø 100 1033719100 □ | □ |
| Ø 90 1033718600 ■ | ■ | Ø 115 1033718900 ■ | ■ |
| Ø 135 1033718300 ○● | ○● | Ø 175 1033718700 ○● | ○● |
| Ø 150 1033718400 ▲ | ▲ | Ø 190 1033719000 ▲ | ▲ |
| Ø 235 1033718100 + | + | | |
| Ø 260 1033718000 + | + | | |

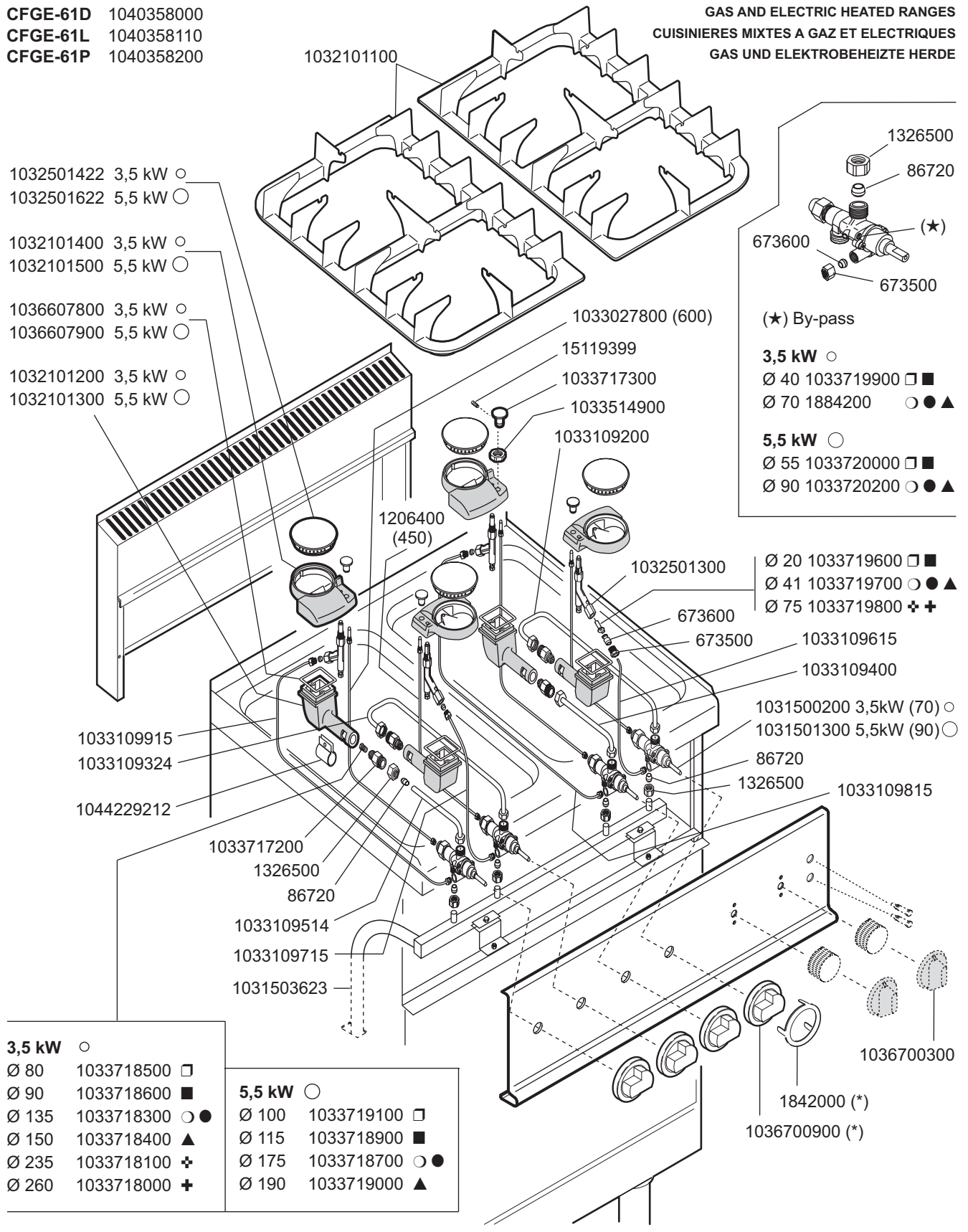

ID GAS: □ G30/50 ■ G30/29 ○ G20/20 ● G25/25 ▲ G25/20 + G120/8 + G110/8

 MARENO INDUSTRIE ALI spa Mareno di Piave (TV)	ELABORATO:	APPROVATO:	GRUPPO:	DENOMINAZIONE:		
	G.Z.		Serie 600 Snack - Cucine	Impianto gas - Mobile		
	DATA:	DATA:	PARTICOLARE:	REV. N.	DEL	DISEGNO N.
	10 Set 1996	10 Set 1996	Disegno esploso per ricambi	▼ Z01	▼ 0106	▼ 3.6.29
SOST. DIS.	Z01.0401.3.6.29.CFG		CE			

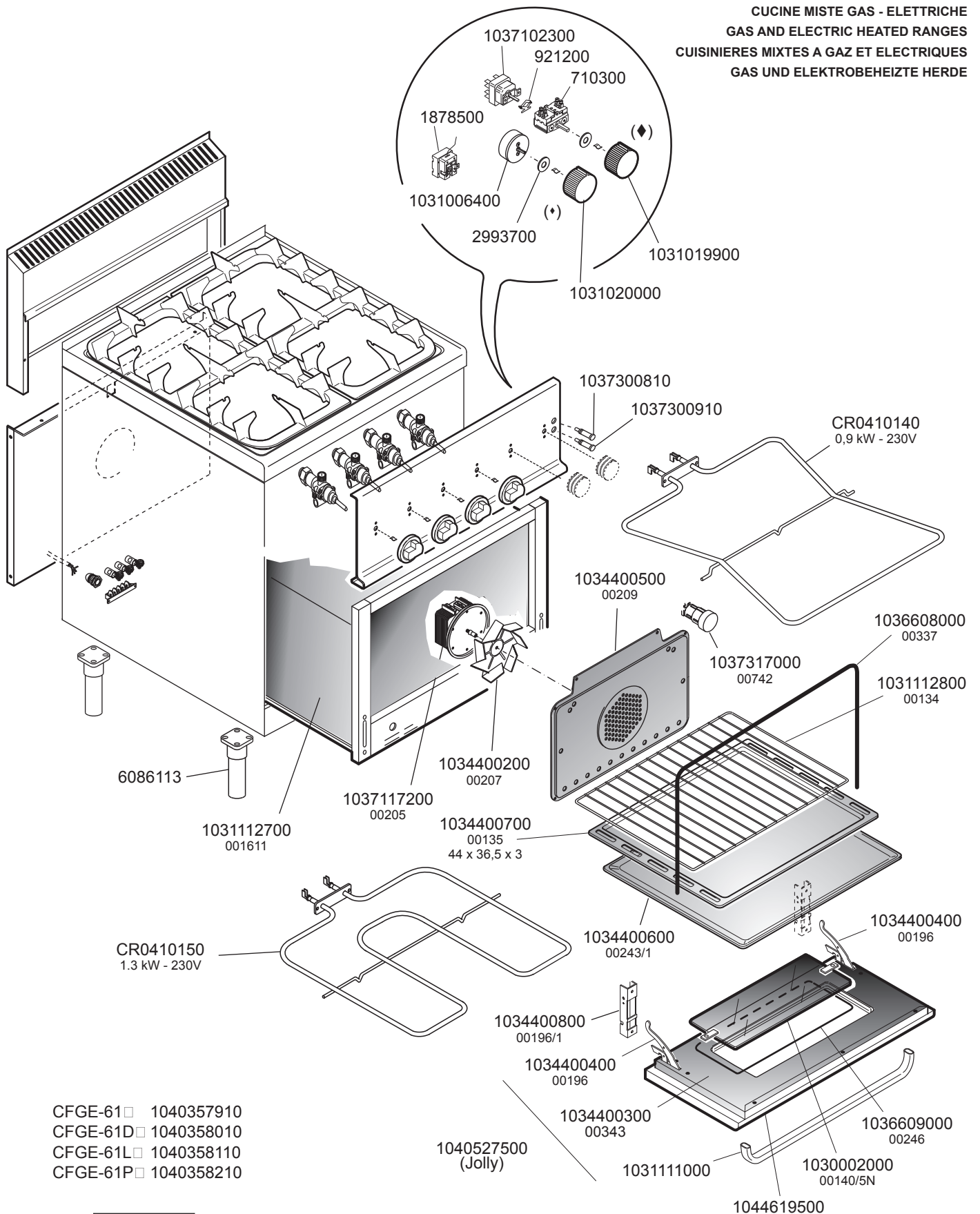

CUCINE MISTE GAS - ELETTRICHE
 GAS AND ELECTRIC HEATED RANGES
 CUISINIÈRES MIXTES A GAZ ET ELECTRIQUES
 GAS UND ELEKTROBEHEIZTE HERDE



- CFGE-61□ 1040357910
- CFGE-61D□ 1040358010
- CFGE-61L□ 1040358110
- CFGE-61P□ 1040358210

02.2003

◆ Contaminuti - Timer ◆ Termostato - Thermostat

 MARENO INDUSTRIE ALI spa Mareno di Piave (TV)	ELABORATO:	APPROVATO:	GRUPPO:	DENOMINAZIONE:		
	G.Z.		Serie 600 Snack - Jolly	Impianto elettrico forno e Mobile		
	DATA:	DATA:	PARTICOLARE:	REV. N.	DEL	DISEGNO N.
	20 Mar 2000	20 Mar 2000	Disegno esploso per ricambi	Z03	0106	3.6.54
SOST. DIS.	Z02.0802.3.6.54.CFGE					

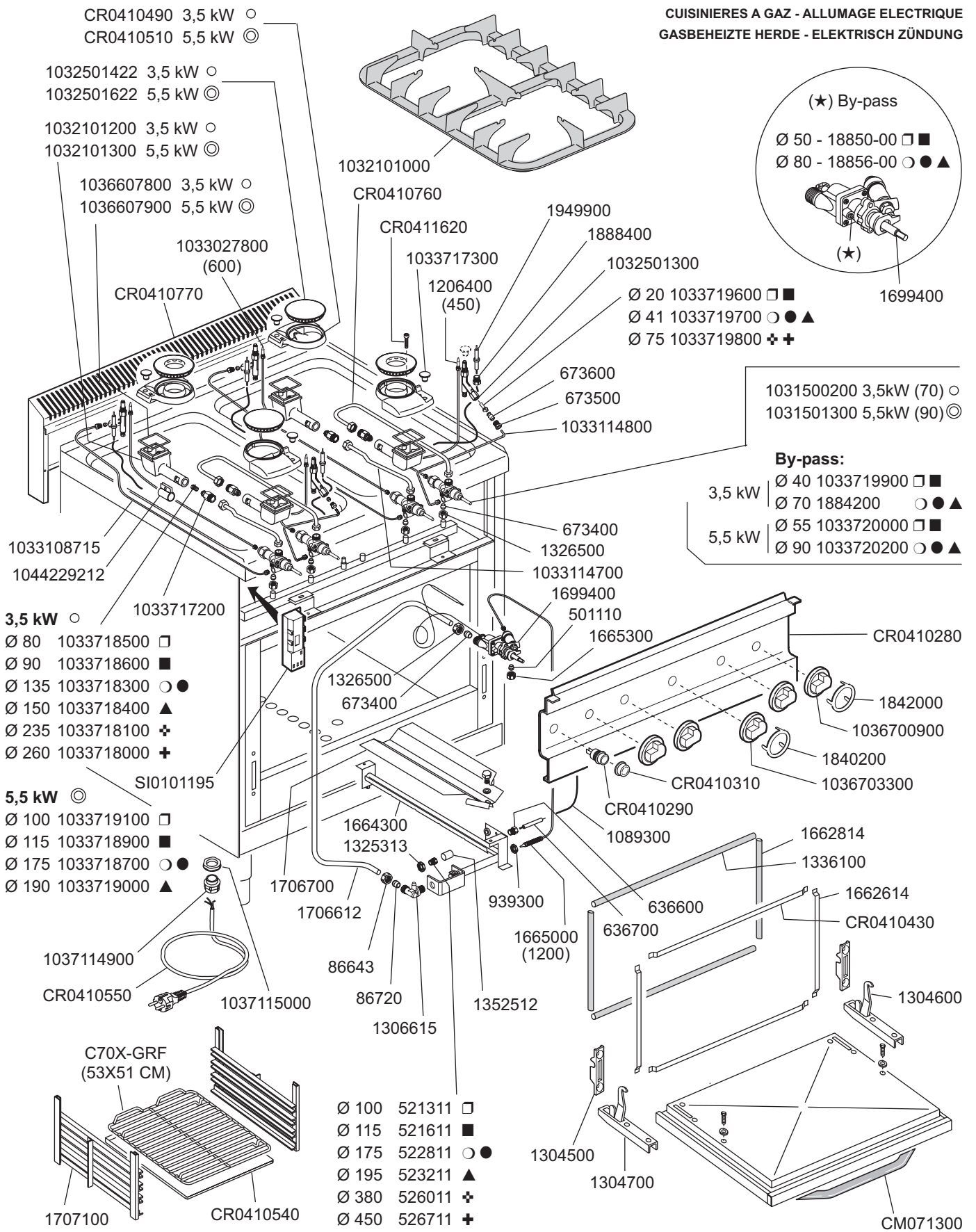

ID GAS: □ G30/50 ■ G30/29 ○ G20/20 ● G25/25 ▲ G25/20 + G120/8 + G110/8

ELABORATO: G.Z.	APPROVATO:	GRUPPO: Serie 600 Snack	DENOMINAZIONE: Impianto gas - Mobile - Acc. elettrica		
DATA: 10 Feb 2004	DATA: 10 Feb 2004	PARTICOLARE: Disegno esploso per ricambi	REV. N. Z00	DEL 0204	DISEGNO N. 3.6.63.CFM
SOST. DIS.					

FTG-40B 1040351830
 FTG-40BR 1040352590
 FTG-60B 1040351930
 FTG-80B 1040352130
 FTG-60BR 1040352030
 FTG-60BRR 1040352690
 FTG-80BR 1040352230
 FTG-40BLC 1040361300
 FTG-60BLC 1040360310
 FTG-80BLC 1040352790

FRY TOP BASSI A GAS
GAS-HEATED FRY TOPS
GRILLADES A GAZ
GASBEHEIZTE BRAT- UND GRILLPLATTEN

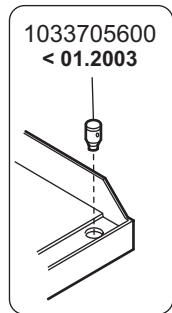

1033705600
 < 01.2003

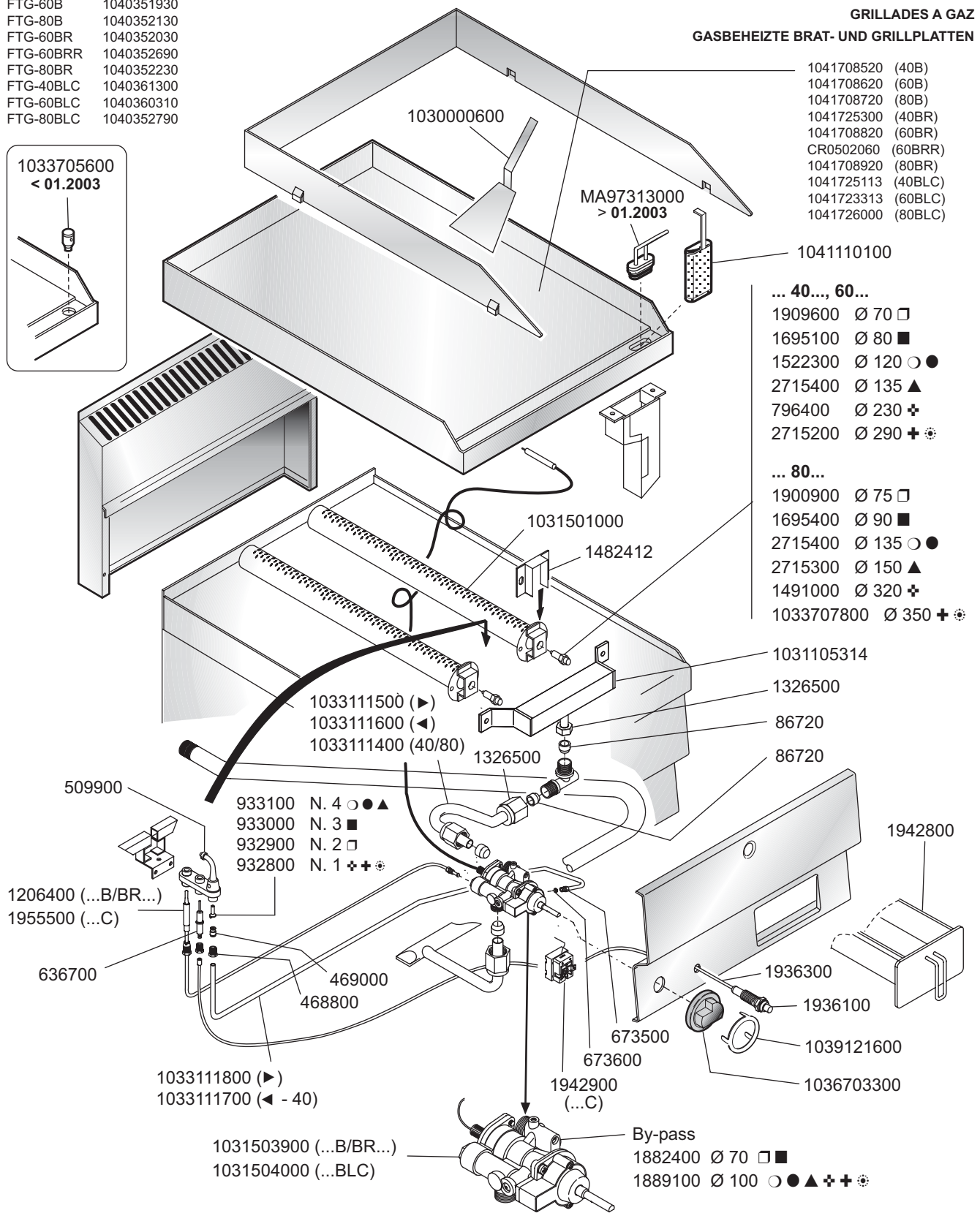

- 1041708520 (40B)
- 1041708620 (60B)
- 1041708720 (80B)
- 1041725300 (40BR)
- 1041708820 (60BR)
- CR0502060 (60BRR)
- 1041708920 (80BR)
- 1041725113 (40BLC)
- 1041723313 (60BLC)
- 1041726000 (80BLC)

... 40..., 60...

- 1909600 Ø 70 □
- 1695100 Ø 80 ■
- 1522300 Ø 120 ○ ●
- 2715400 Ø 135 ▲
- 796400 Ø 230 ✚
- 2715200 Ø 290 ✚ ☼

... 80...

- 1900900 Ø 75 □
- 1695400 Ø 90 ■
- 2715400 Ø 135 ○ ●
- 2715300 Ø 150 ▲
- 1491000 Ø 320 ✚
- 1033707800 Ø 350 ✚ ☼

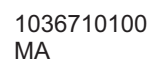

ID GAS: □ G30/50 ■ G30/29 ○ G20/20 ● G25/25 ▲ G25/20 ✚ G120/8 ✚ G110/8 ☼ G140/8

 MARENO INDUSTRIE ALI spa Mareno di Piave (TV)	ELABORATO:	APPROVATO:	GRUPPO:	DENOMINAZIONE:		
	G.Z. (1)		Serie 600 Snack (PEL 25 ST)	Impianto gas - Mobile		
	DATA:	DATA:	PARTICOLARE:	REV. N.	DEL	DISSEGNO N.
	24 Mag 1999	24 Mag 1999	Disegno esploso per ricambi	Z03	0406	3.6.55
SOST. DIS.	Z03.0106.3.6.55		CE			

BIG-40 1040350820
 BIG-60 1040350920

BISTECCHIERE A GAS
 GAS HEATED GRILL
 GRILLADES A GAZ
 GASBEHEIZTE BRAT- UND GRILLPLATTEN

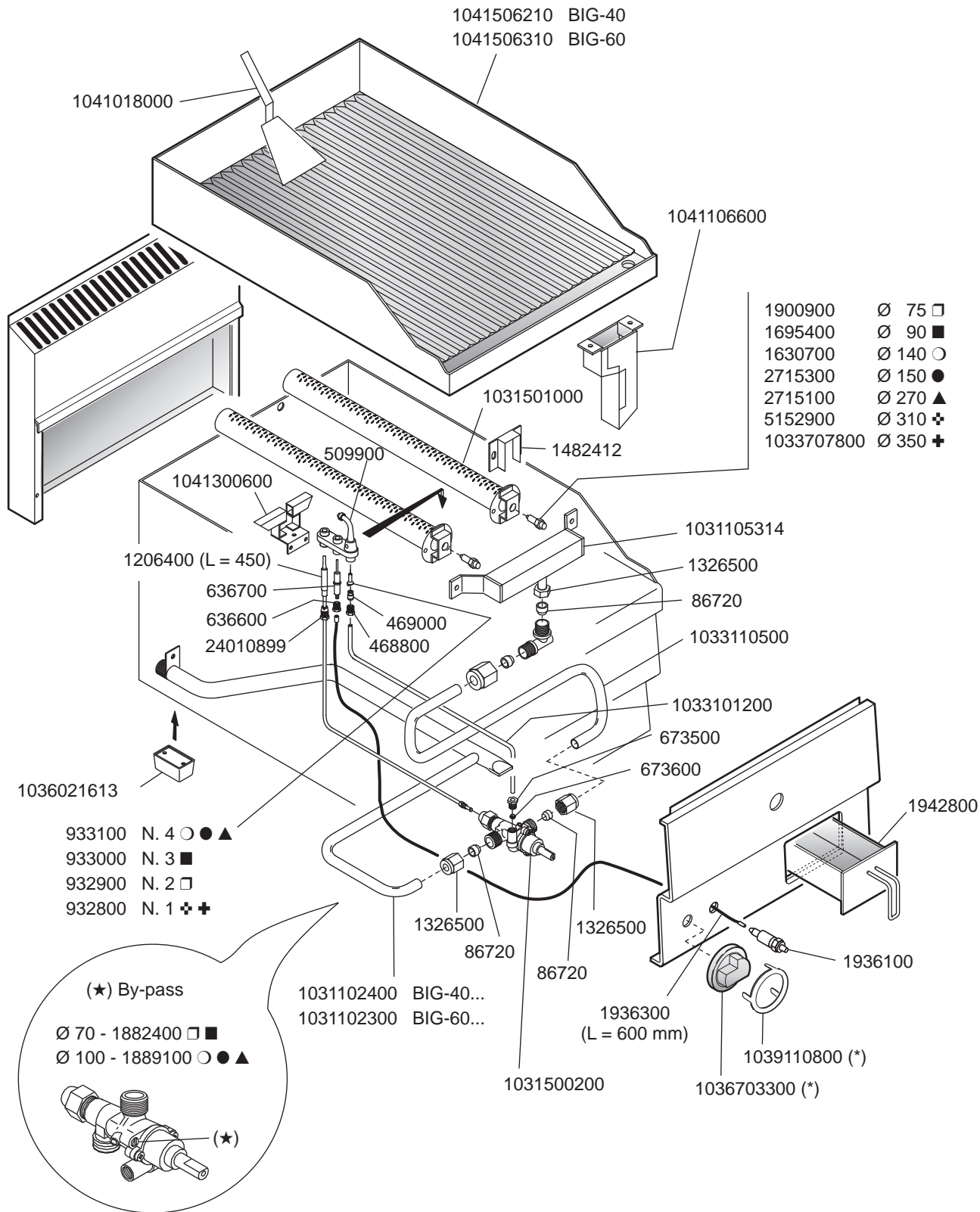

ID GAS: □ G30/50 ■ G30/29 ○ G20/20 ● G25/25 ▲ G25/20 ✚ G120/8 ✚ G110/8

ELABORATO:	APPROVATO:	GRUPPO:	DENOMINAZIONE:		
G.Z.		Serie 600 Snack	Impianto gas - Mobile		
DATA:	DATA:	PARTICOLARE:	REV. N.	DEL	DISEGNO N.
29 Mar 2001	29 Mar 2001	Disegno esploso per ricambi	▼	▼	▼
SOST. DIS.	A01.9610.3.6.06.BIG	CE	Z01	0103	3.6.06.BIG

PLG-40 1040351010
 PLG-80 1040351110

GRIGLIA BISTECCHIERA (A PIETRA LAVICA) A GAS
 GAS HEATED CHAR GRILL
 GRILLADE CHARCOAL A GAZ
 GASBEHEIZTE GLÜHSTEINGERAT

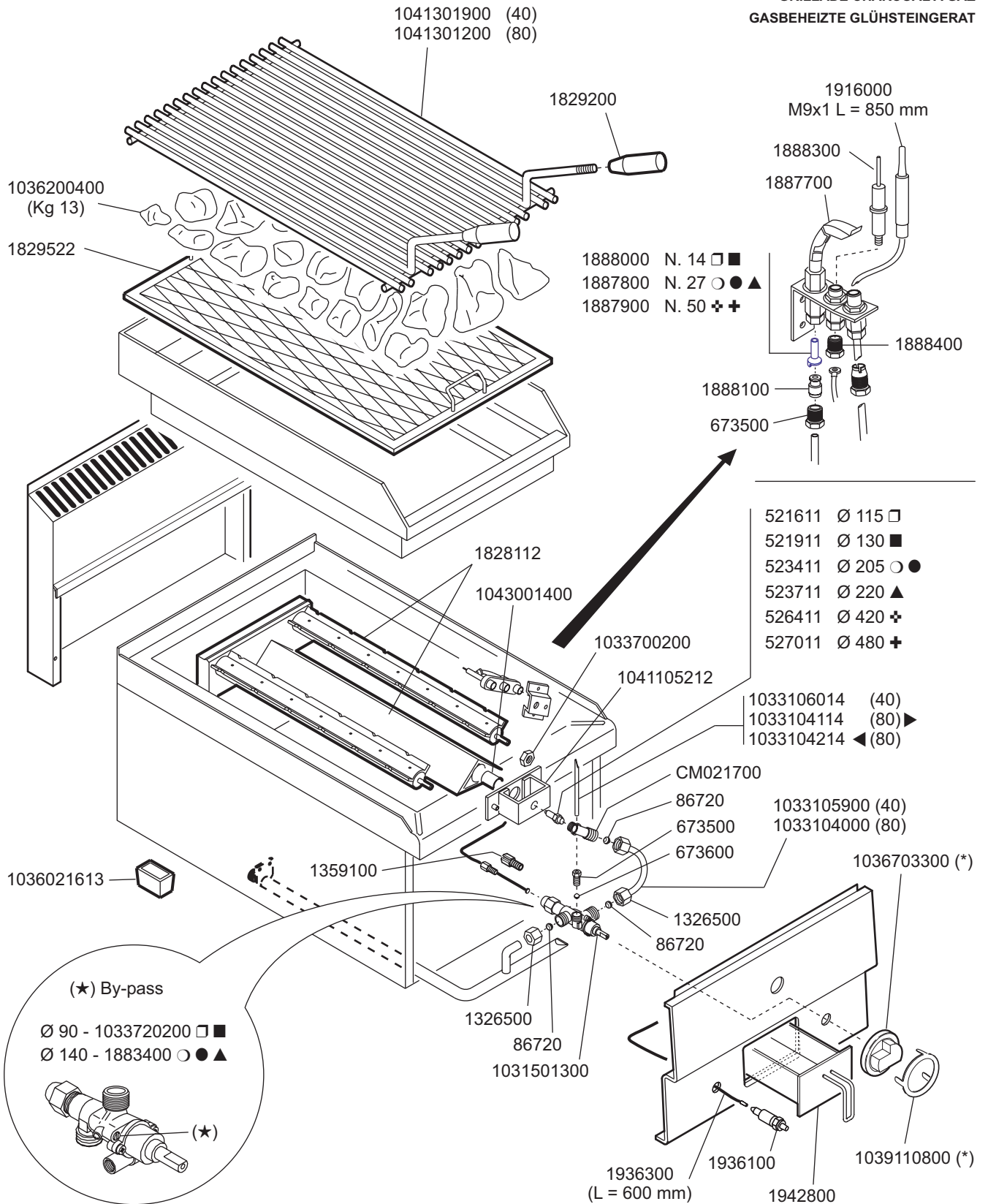

1036702900
 MA,



ID GAS: □ G30/50 ■ G30/29 ○ G20/20 ● G25/25 ▲ G25/20 ✚ G120/8 ✛ G110/8

 MARENO INDUSTRIE ALI spa Mareno di Piave (TV)	ELABORATO:	APPROVATO:	GRUPPO:	DENOMINAZIONE:		
	G.Z.		Serie 600 Snack	Impianto gas - Mobile		
	DATA:	DATA:	PARTICOLARE:	REV. N.	DEL	DISEGNO N.
	12 Apr 2000	12 Apr 2000	Disegno esploso per ricambi	▼	▼	▼
SOST. DIS.	P01.9609.3.6.07.PLG		CE	Z02	0106	3.6.07.PLG

FQG-40 1040351410
 FQG-60 1040351510

FRIGGITRICI A GAS
 GAS HEATED FRYERS
 FRITEUSES A GAZ
 GASBEHEIZTE FRITZEUSEN

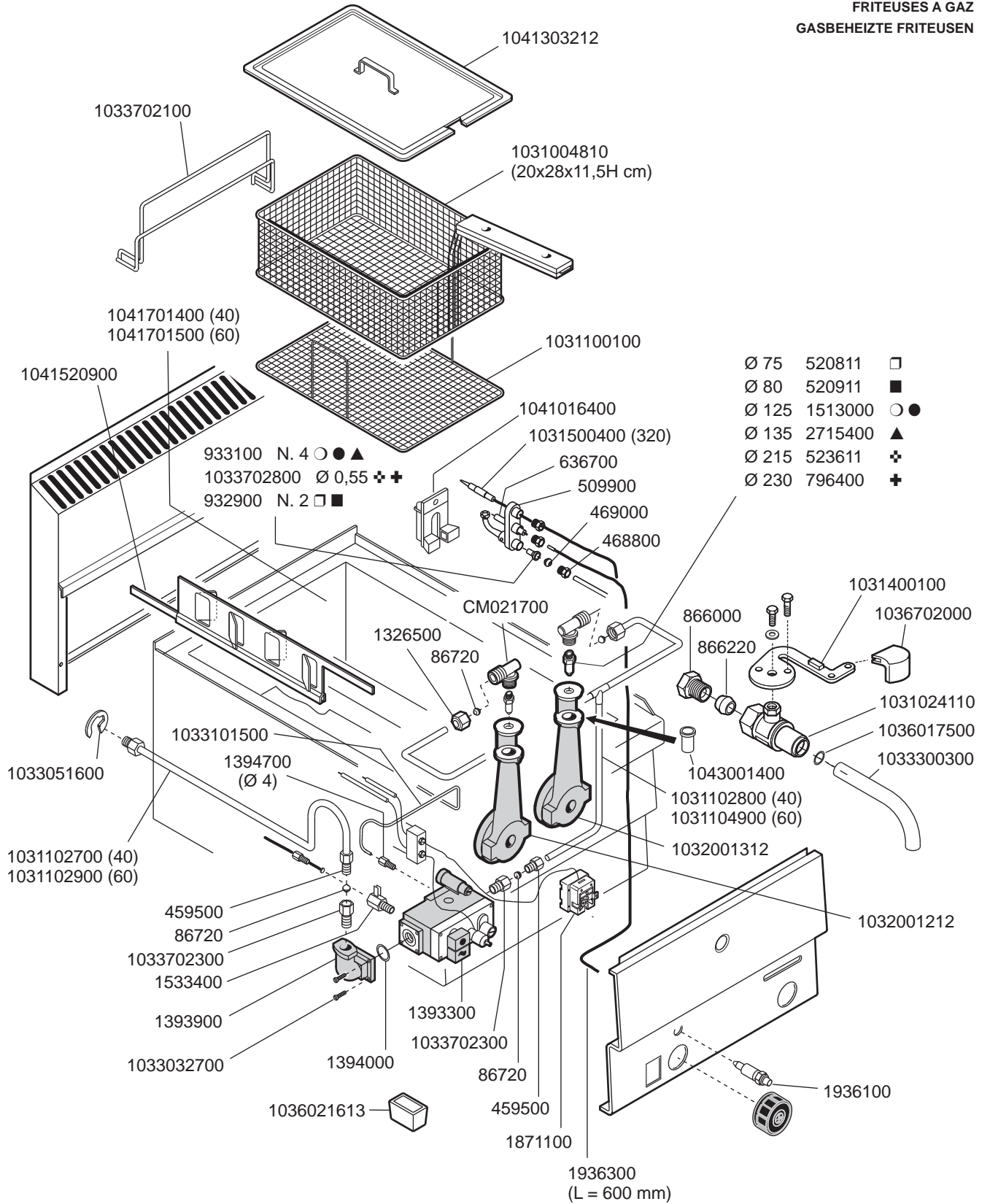

1393500
MA

ID GAS: □ G30/50 ■ G30/29 ○ G20/20 ● G25/25 ▲ G25/20 ✚ G120/8 ✚ G110/8

ELABORATO: G.Z.	APPROVATO:	GRUPPO: Serie 600 Snack	DENOMINAZIONE: Impianto gas - Mobile		
DATA: 10 Set 1996	DATA: 10 Set 1996	PARTICOLARE: Disegno esploso per ricambi	REV. N. Z02	DEL 0101	DISEGNO N. 3.6.08.FQG
SOST. DIS. P01.9609.3.6.08.FQG		CE			

BMG-40 1040351210
 BMG-60 1040351310

BAGNOMARIA A GAS
GAS-HEATED BAIN MARIE
BAIN MARIE A GAZ
GASBEHEIZTE WASSERBÄDER

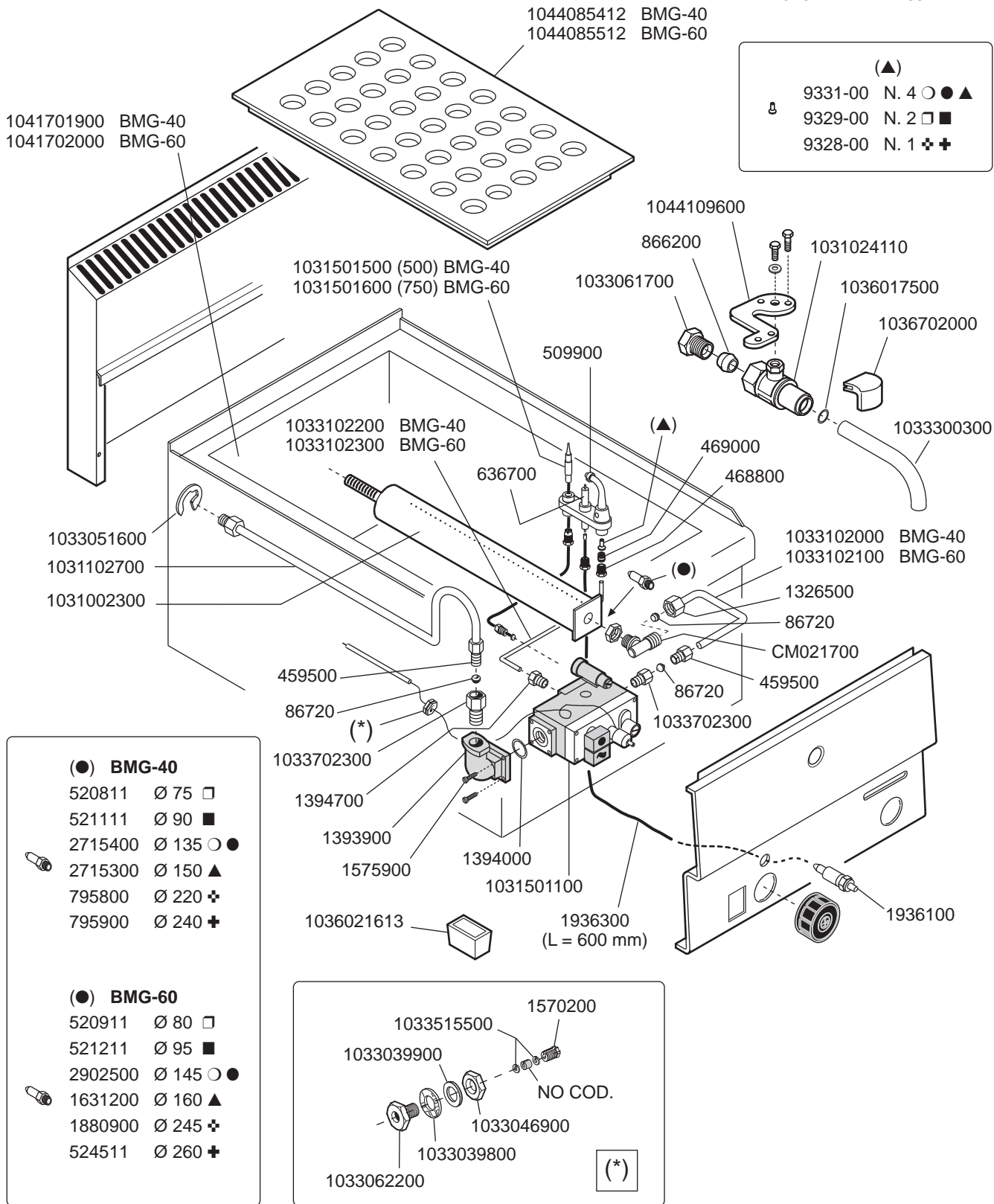

ID GAS: □ G30/50 ■ G30/29 ○ G20/20 ● G25/25 ▲ G25/20 ✚ G120/8 ✛ G110/8

ELABORATO:	APPROVATO:	GRUPPO:	DENOMINAZIONE:		
G.Z.		Serie 600 Snack	Impianto gas - Mobile		
DATA:	DATA:	PARTICOLARE:	REV. N.	DEL	DISEGNO N.
10 Set 1996	10 Set 1996	Disegno esploso per ricambi	▼	▼	▼
SOST. DIS.	P01.9609.3.6.09.BMG	CE	Z02	0101	3.6.09.BMG

BRG-40 1040351610
BRG-40G 1040351710

BRASIERE A GAS
GAS HEATED BRATT PANS
SAUTEUSES A GAZ
GASBEHEIZT BRATPFANNEN

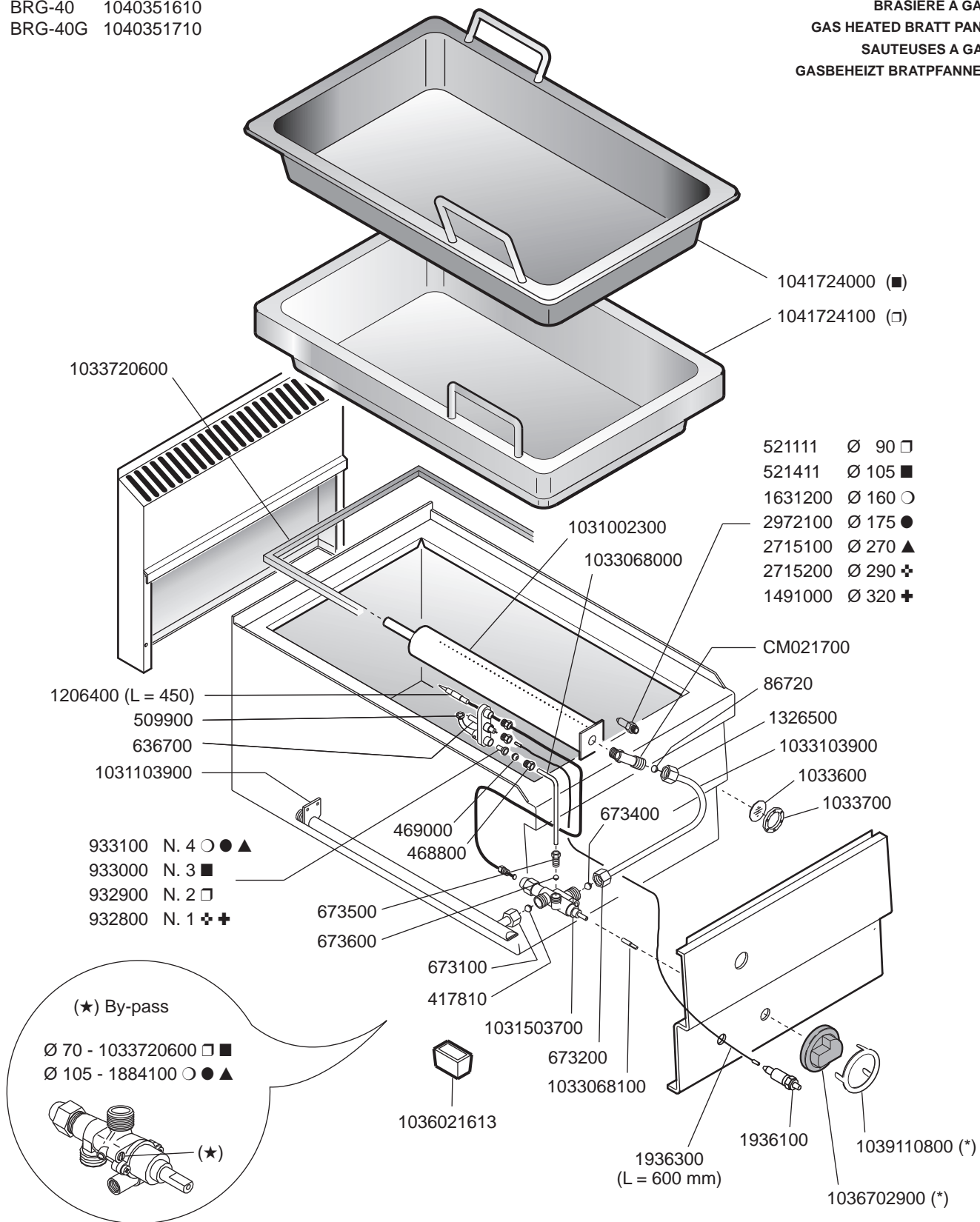

□ (AISI 304) Acciaio Inox - Stainless Steel - Acier Inox - Chromnickelstahl

■ Ghisa - Cast iron - Fonte - Gußeisen



1036702900
MA



ID GAS:

□ G30/50

■ G30/29

○ G20/20

● G25/25

▲ G25/20

✚ G120/8

✚ G110/8



ELABORATO:	APPROVATO:	GRUPPO:	DENOMINAZIONE:		
G.Z.		Serie 600 Snack	Impianto gas - Mobile		
DATA:	DATA:	PARTICOLARE:	REV. N.	DEL	DISEGNO N.
12 Set 2000	12 Set 2000	Disegno esploso per ricambi	▼	▼	▼
SOST. DIS.	P01.9609.3.6.10.BRG	CE	Z02	0103	3.6.10.BRG

PL-40 □ 1040518110
 PL-60 □ 1040518210

PL-6 □ 1040518310

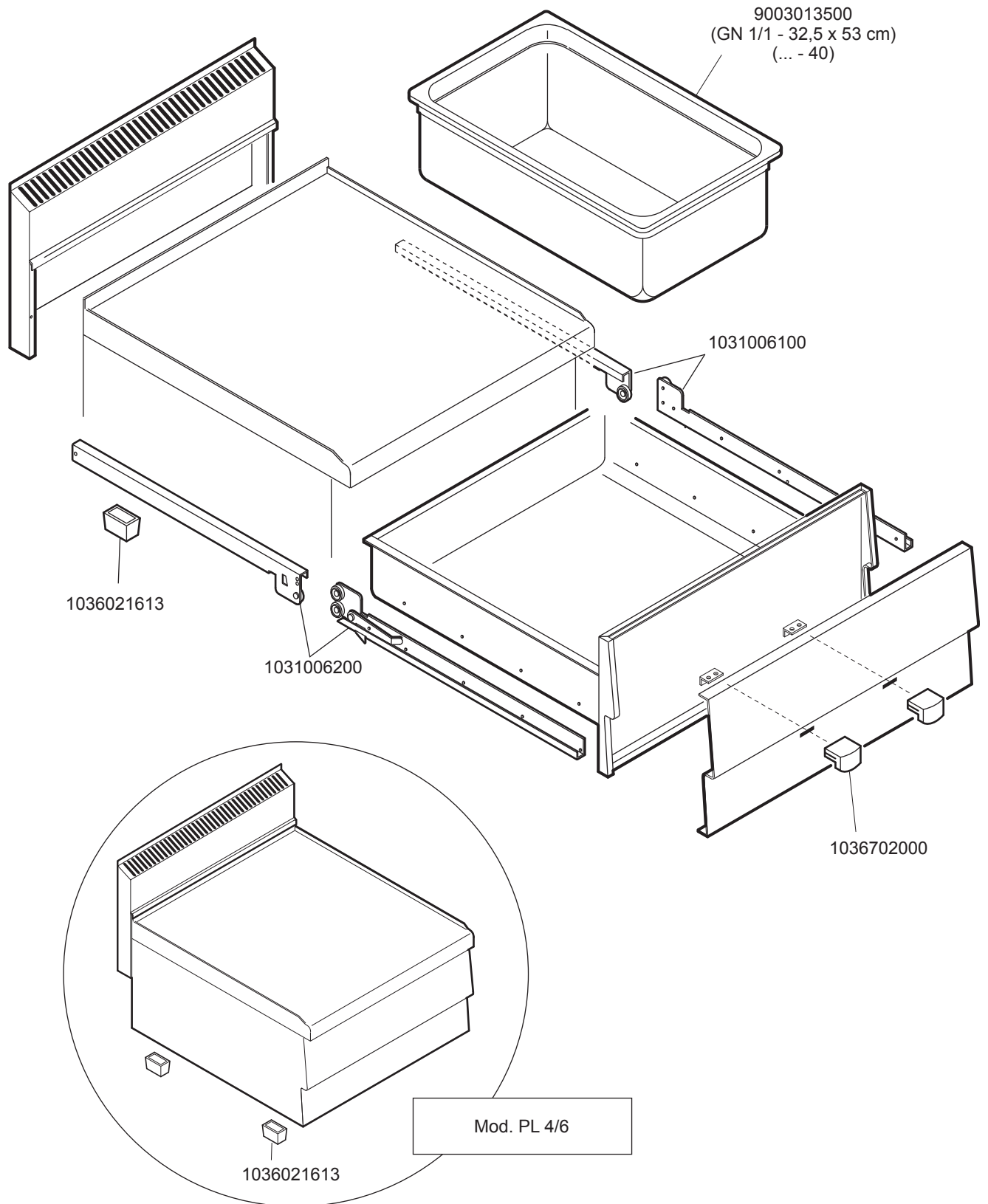
ELEMENTI NEUTRI CON CASSETTO
 WORK UNITS WITH DRAWER
 ELEMENTS NEUTRES AVEC TIROIR
 ANBAU ELEMENTE MIT SCHUBLADE



 MARENO INDUSTRIES ALI spa Mareno di Piave (TV)	ELABORATO:	APPROVATO:	GRUPPO:	DENOMINAZIONE:		
	G.Z.		Serie 600 Snack	Mobile		
	DATA:	DATA:	PARTICOLARE:	REV. N.	DEL	DISEGNO N.
	10 Giu 1996	10 Giu 1996	Disegno esploso per ricambi	▼	▼	▼
SOST. DIS.	Z01.0101.3.6.33.PLN			Z01	0106	3.6.33.PLN

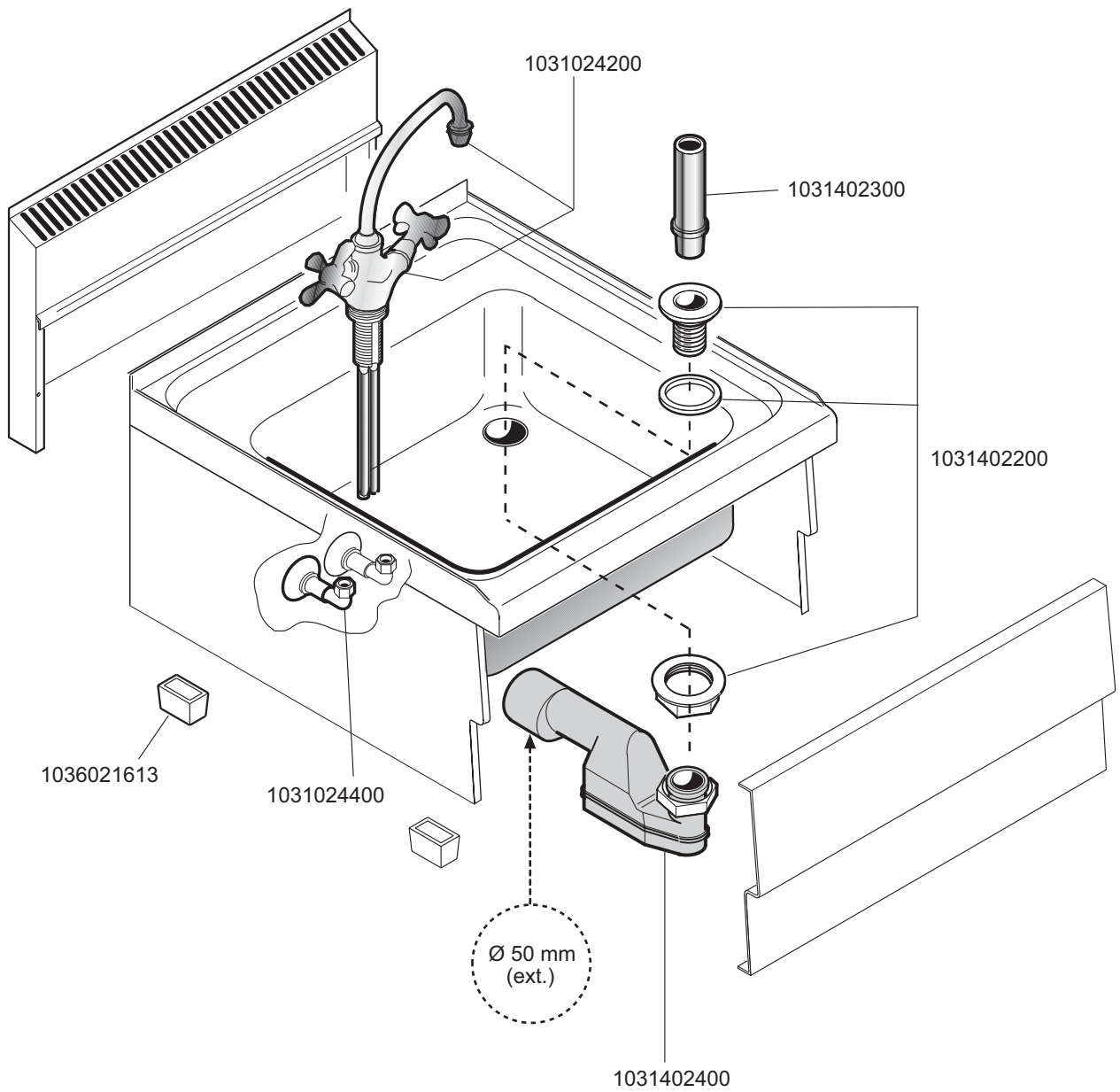

 MARENO INDUSTRIE ALI spa Mareno di Piave (TV)	ELABORATO:	APPROVATO:	GRUPPO:	DENOMINAZIONE:		
	G.Z.		Serie 600 Snack	Impianto idraulico - Mobile		
	DATA:	DATA:	PARTICOLARE:	REV. N.	DEL	DISEGNO N.
	10 Lug 1996	10 Lug 1996	Disegno esploso per ricambi	▼	▼	▼
SOST. DIS.	Z01.0101.3.6.34.LA6			Z01	0106	3.6.34.LA6

Mod.
 M-40 1040503320
 M-60 1040503420
 M-80 1040503520
 M-100 1040503620
 M-120 1040503720
 M-140 1040503820
 M-160 1040503920
 M-180 1040504020
 M-180 1040504120

Mod.
 P-40D 1040514900
 P-40S 1040515000
 P-60D 1040515100
 P-60S 1040515200

Mod.
 CS-40 1040515400
 CS-60 1040515500

BASI A GIORNO
OPEN BASE
PLACARDS OUVERTS
OFFENE UNTERBAUTEN

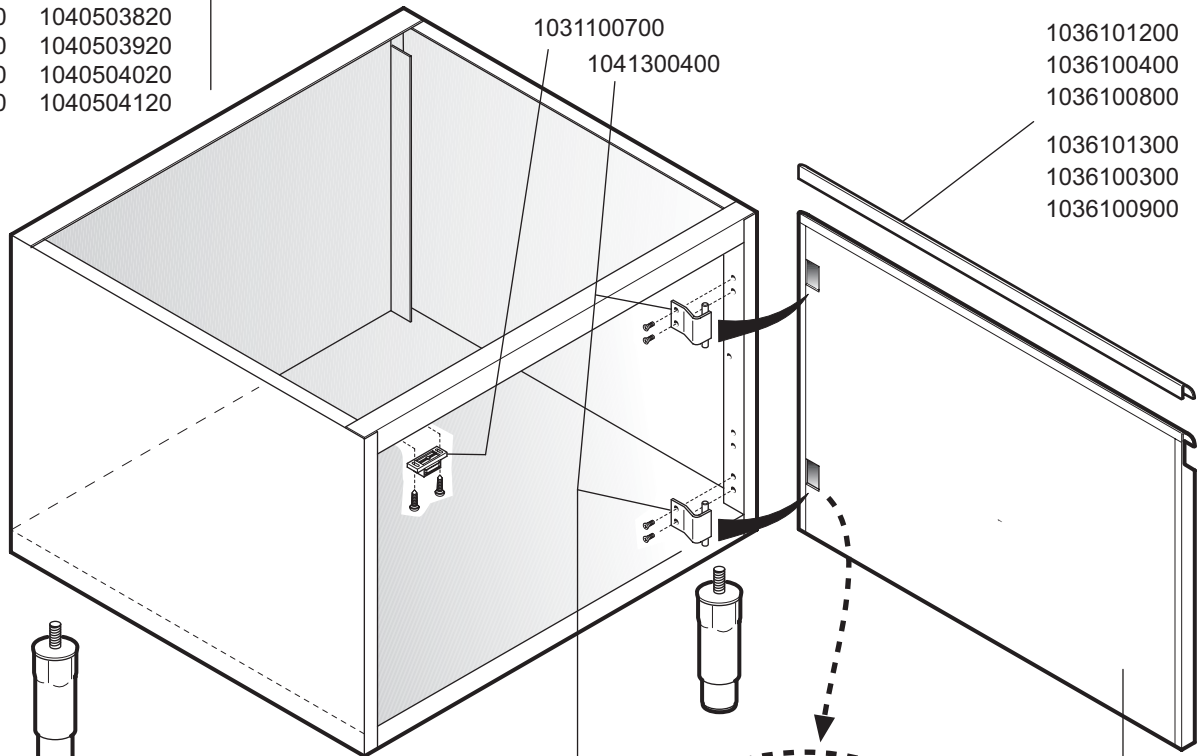

1036101200 40 ■
 1036100400 40 □
 1036100800 40 ○
 1036101300 60 ■
 1036100300 60 □
 1036100900 60 ○

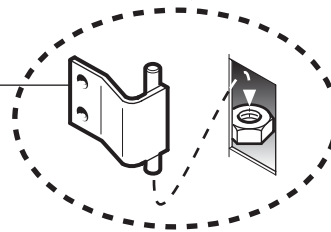
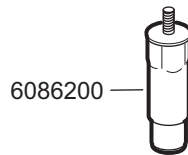

1041504500 40D
 1041504300 40S
 1041504600 60D
 1041504400 60S

9003013500
 (GN 1/1 - 32,5 x 53 cm)
 (... - 40)

Old

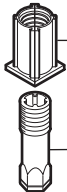

1758400

40x40 mm

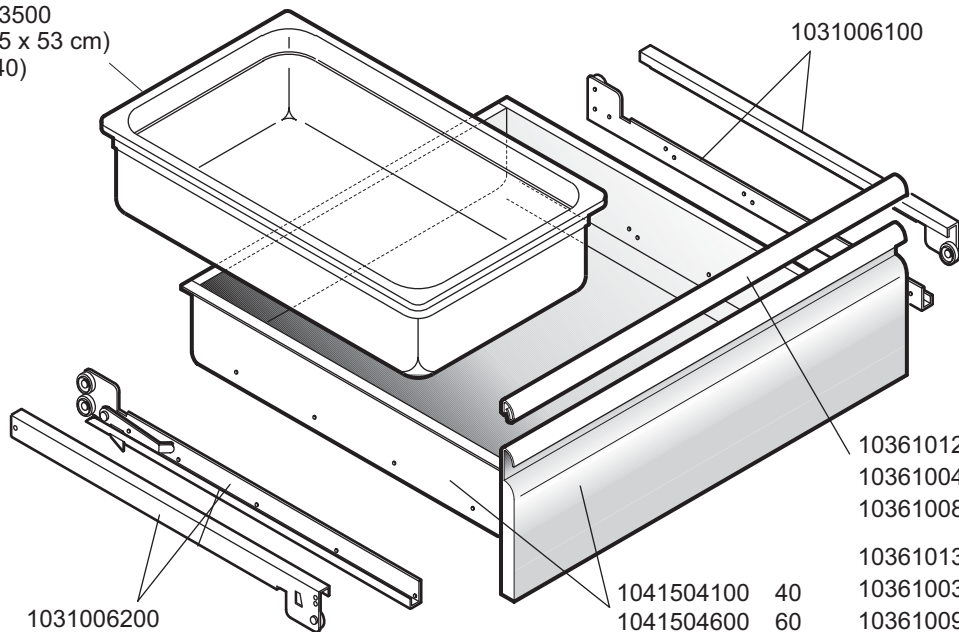

1036101200 40 ■
 1036100400 40 □
 1036100800 40 ○
 1036101300 60 ■
 1036100300 60 □
 1036100900 60 ○

□ Verde - Green - Vert - Grün

■ Nero - Black - Noir - Schwarz

○ Rosso - Red - Rouge - Rot

 MARENO INDUSTRIE ALI spa Mareno di Piave (TV)	ELABORATO:	APPROVATO:	GRUPPO:	DENOMINAZIONE:		
	G.Z.		Serie 600 Snack	Mobile		
	DATA:	DATA:	PARTICOLARE:	REV. N.	DEL	DISEGNO N.
	24 Apr 2006	24 Apr 2006	Disegno esploso per ricambi	Z00	0406	3.6.65
SOST. DIS.			