

Drawing stacking kit Convotherm maxx

6.10
10.10

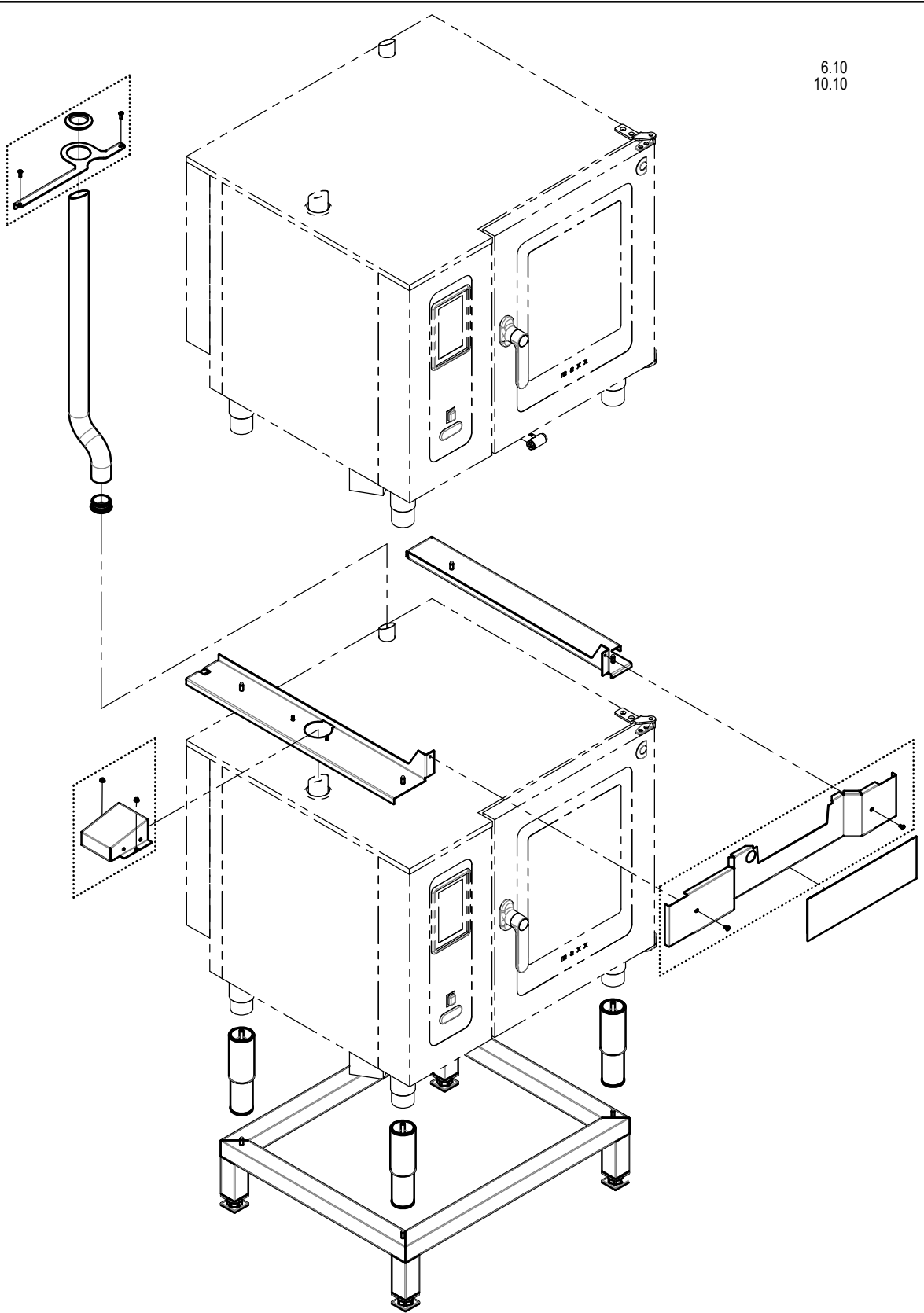

				Drawn	09.07.2020	aneumeie
00	Z-Freigabe	Sep 02, 20	rlammers	App.	Sep 02, 20	rlammers
Rev	Remarks	Date	Name		Date	Name

Laufende Verbesserungen des Produkts können Änderungen der Spezifikationen ohne expliziten Hinweis bedingen. Continuous improvements to the product may mean changes to the specification are made without explicit mention.
 9966809_00 Sep 02, 20 © 2020

Stapelkit (STK) für Gerätegröße 6.10 auf 6.10 / Stacking kit (STK) for unit size 6.10 to 6.10

unteres Gerät auf Gerätefüße Standard
lower unit on appliance feet Standard

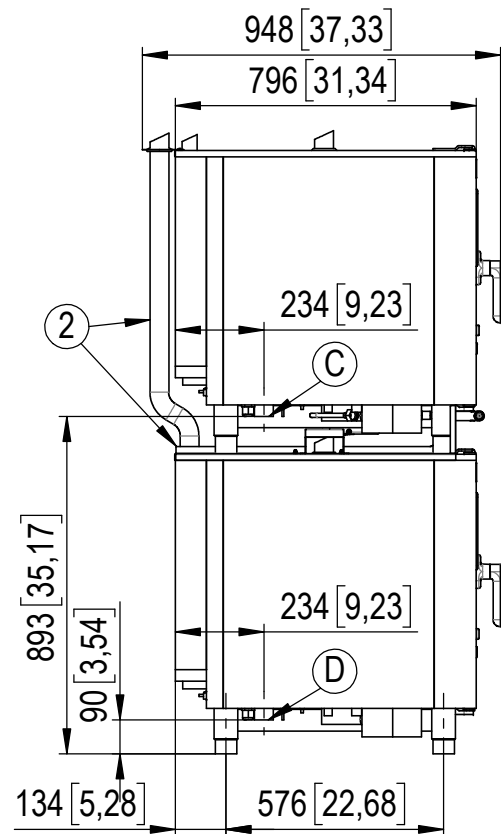
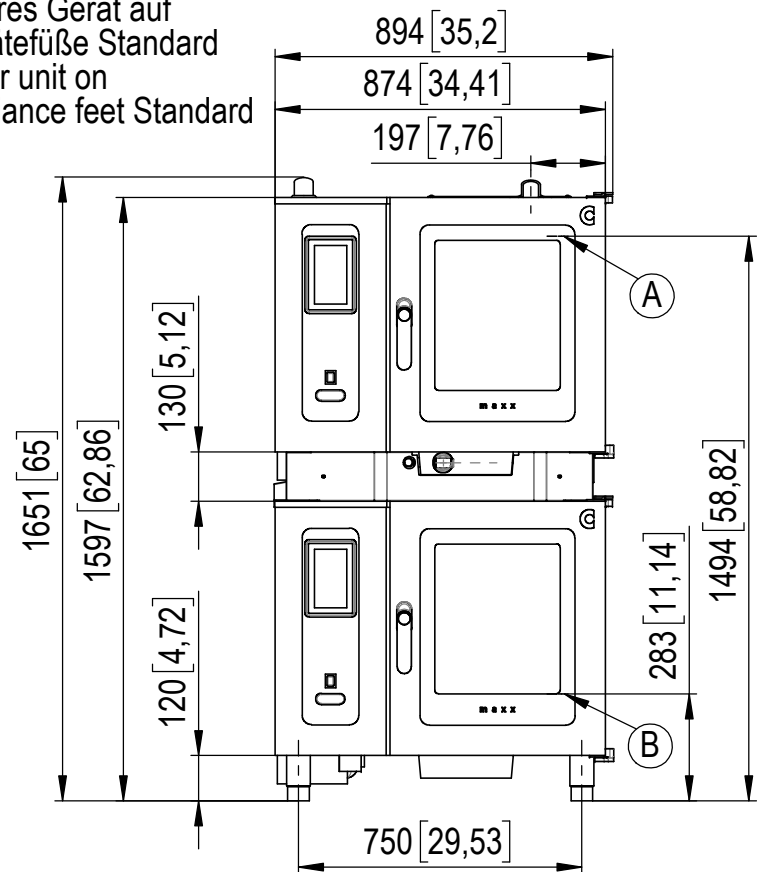

unteres Gerät auf Gerätefüße H = 230mm
lower unit on appliance feet H = 230mm

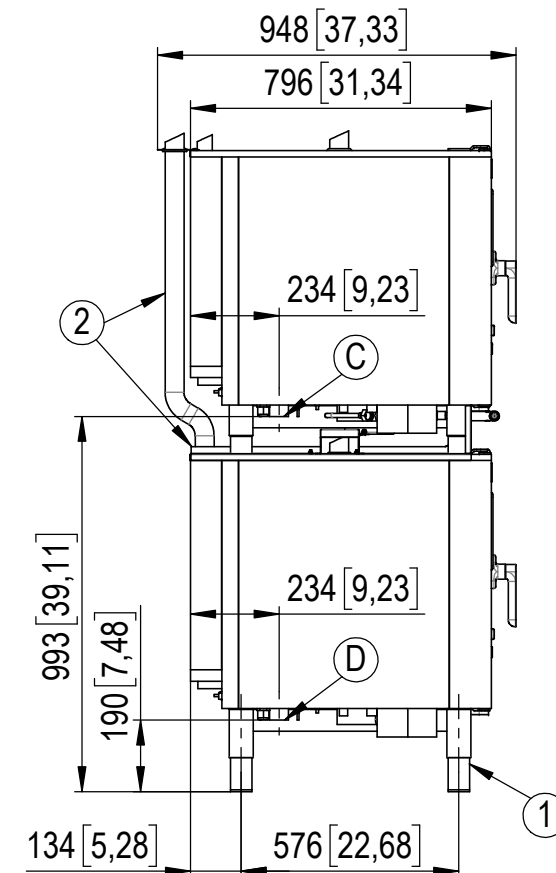
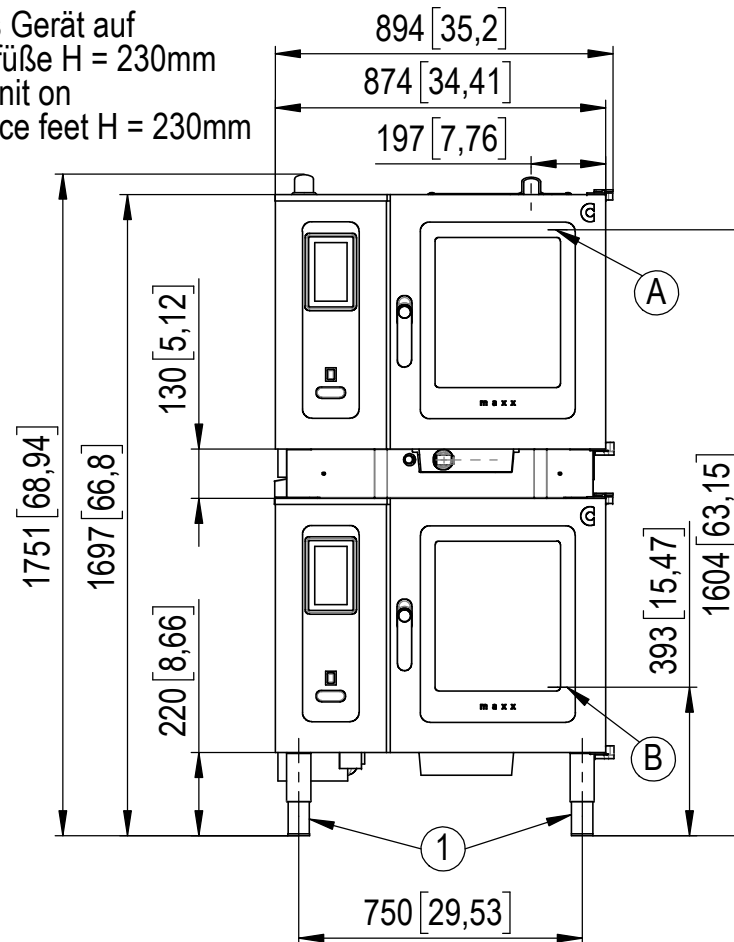

unteres Gerät auf Untergestell (UG)
lower unit on base frame (UG)

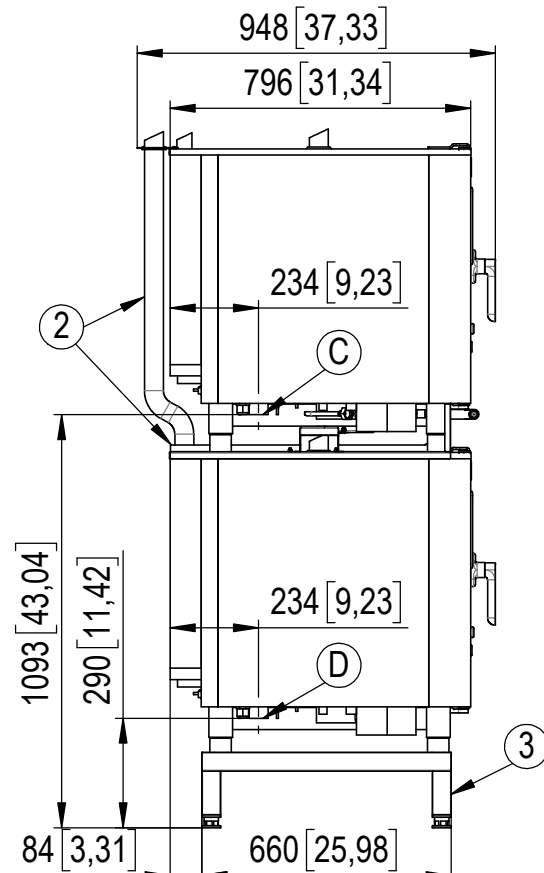
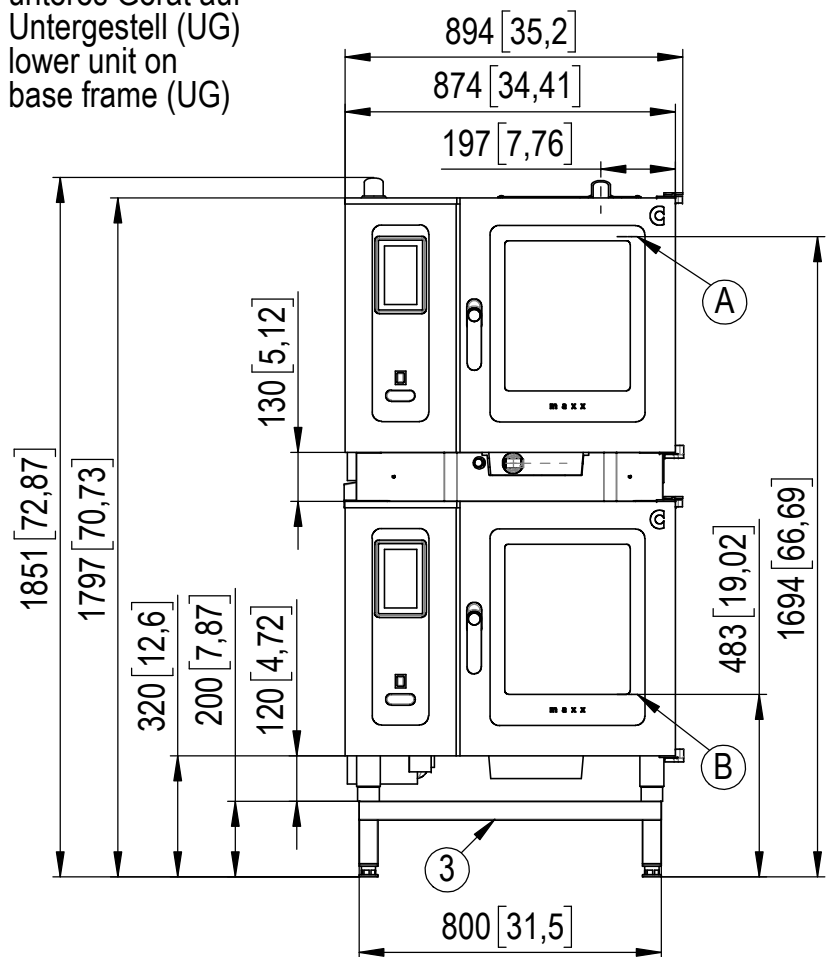

- A: Oberster Einschub/ Upper tray
- B: Tiefster Einschub/ Lower tray
- C: Mittelpunkt oberer Abwasseranschluss DN50/
Center of upper water drainage hole DN50
- D: Mittelpunkt unterer Abwasseranschluss DN50/
Center of lower water drainage hole DN50

Pos.	Teil / Part	Benennung / Description	STK Cmx 6.10 unten / down 6.10 oben / top mit / with Gerätefuß Standard Appl. Feet Standard	STK Cmx 6.10 unten / down 6.10 oben / top mit / with Gerätefuß H=230 Appl. Feet H=230	STK Cmx 6.10 unten / down 6.10 oben / top mit / with Untergestell Stand
1	6267629	Set Gerätefuß 2" 230mm CF	-	1	-
2	6267719	STK 1 3 unt 1 ob Basis kpl CF	1	1	1
3	6267720	UG 1 3 200mm für STK 13 unt 1 ob kpl CF	-	-	1

<p>Convotherm Elektrogeräte GmbH Talstraße 35 82436 Egfling, Deutschland Telefon: +49 (0)8847 67-0 Fax: +49 (0) 8847 414</p>		<p>General Tolerance: DIN ISO 2768 - vL</p>	<p>Material</p>	<p>Revision 00.</p>	<p>Version 9</p>
<p>© 2020</p>		<p>Date Name</p>	<p>Stock Size</p>	<p>Weight 6.91 kg</p>	
<p>00 Z-Freigabe Oct 07, 20 hschweig</p>		<p>Drawn Jun 17, 20 aneumeie</p>	<p>Description</p>		<p>Scale 1:20</p>
<p>Rev Remarks Date Name</p>		<p>Ckd. Oct 07, 20</p>	<p>PDF Cmx eT STK 6.10 auf 6.10/10.10 CF</p>		<p>Size A3</p>
<p>Model No. 6267690</p>		<p>App. Oct 07, 20 hschweig</p>	<p>PDF Cmx eT STK 6.10 on 6.10/10.10 CF</p>		<p>Sheet 1 of 2</p>
<p>DRG.No.</p>		<p>All dimensions in mm [inch] Do not scale</p>		<p>K6267690</p>	
<p>Repl. for</p>		<p>Filename</p>		<p>00054563</p>	

Stapelkit (STK) für Gerätegröße 6.10 auf 10.10 / Stacking kit (STK) for unit size 6.10 to 10.10

unteres Gerät auf Gerätefüße Standard
lower unit on appliance feet Standard

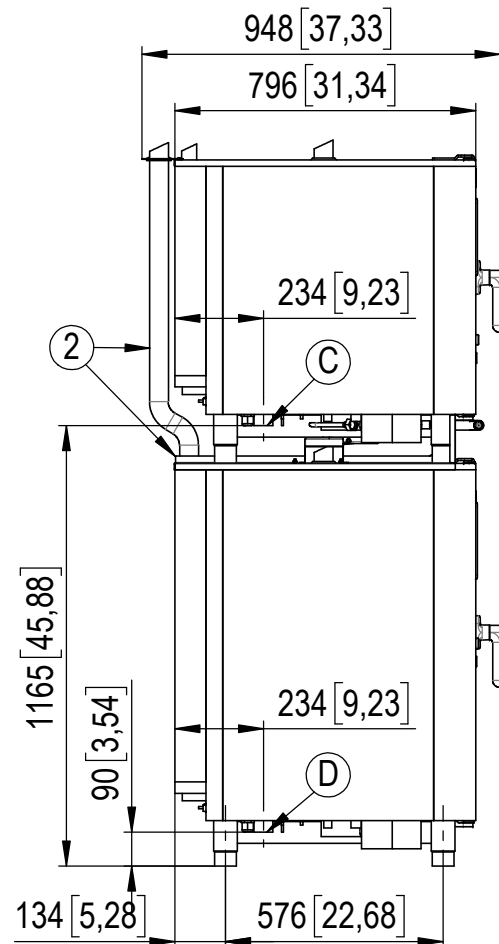
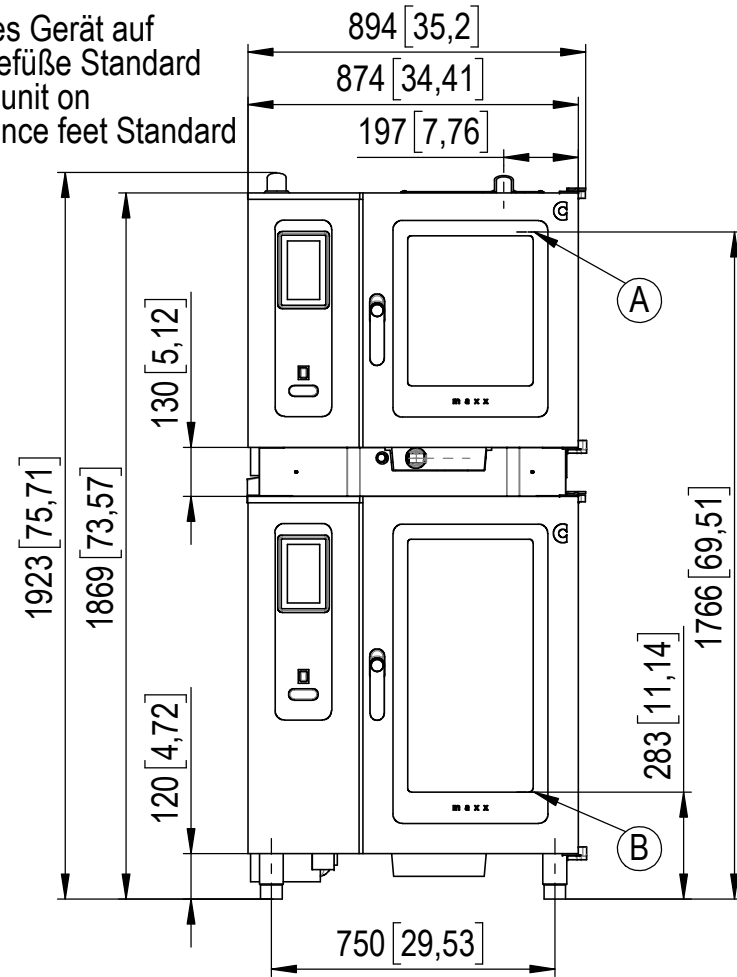

unteres Gerät auf Gerätefüße H = 230mm
lower unit on appliance feet H = 230mm

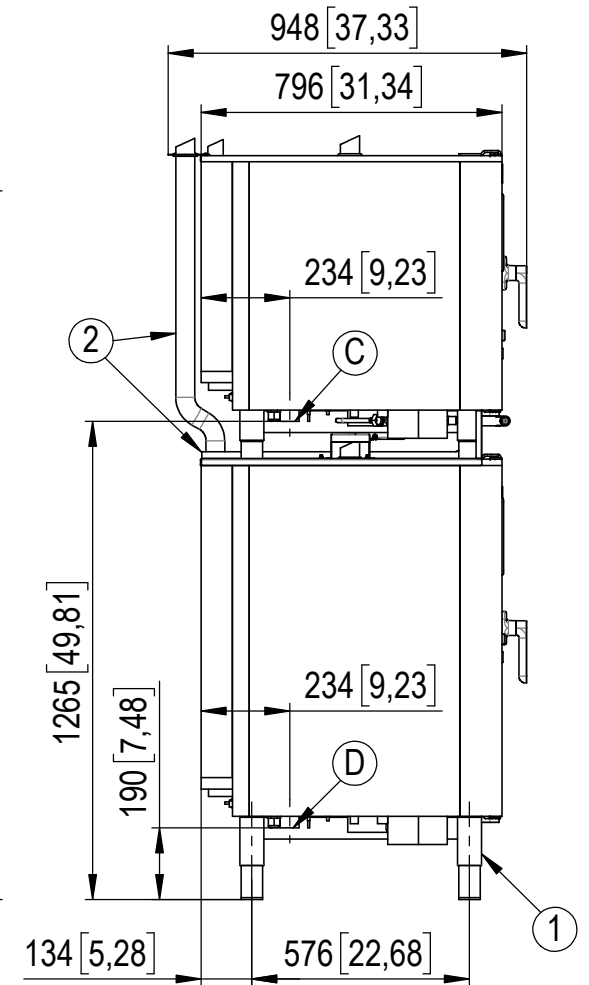
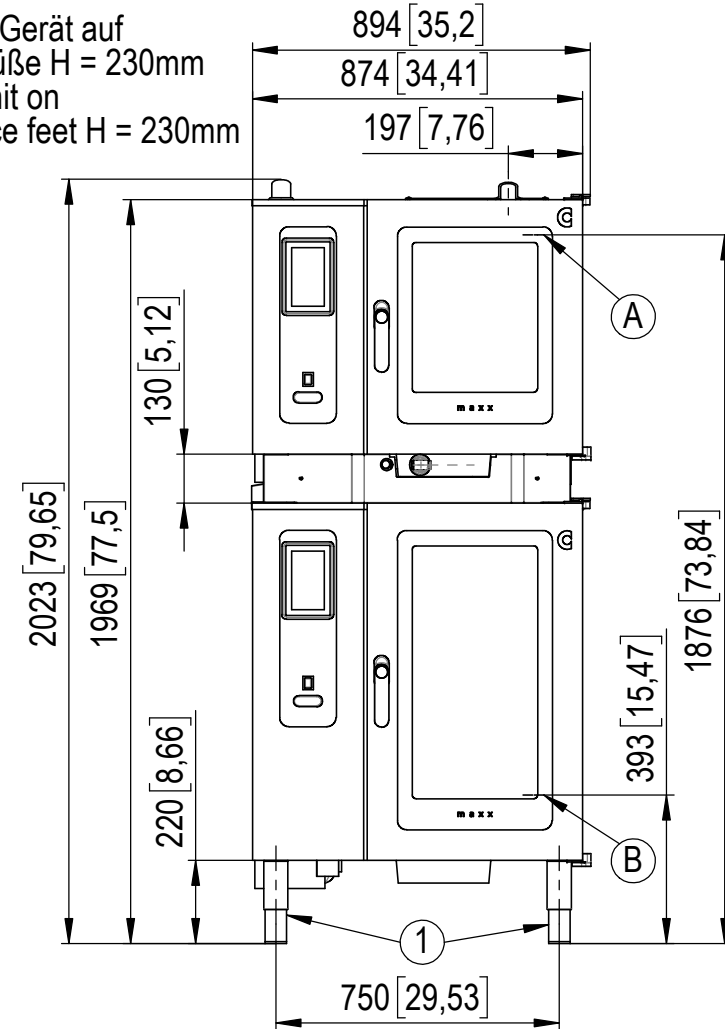

unteres Gerät auf Untergestell (UG)
lower unit on base frame (UG)

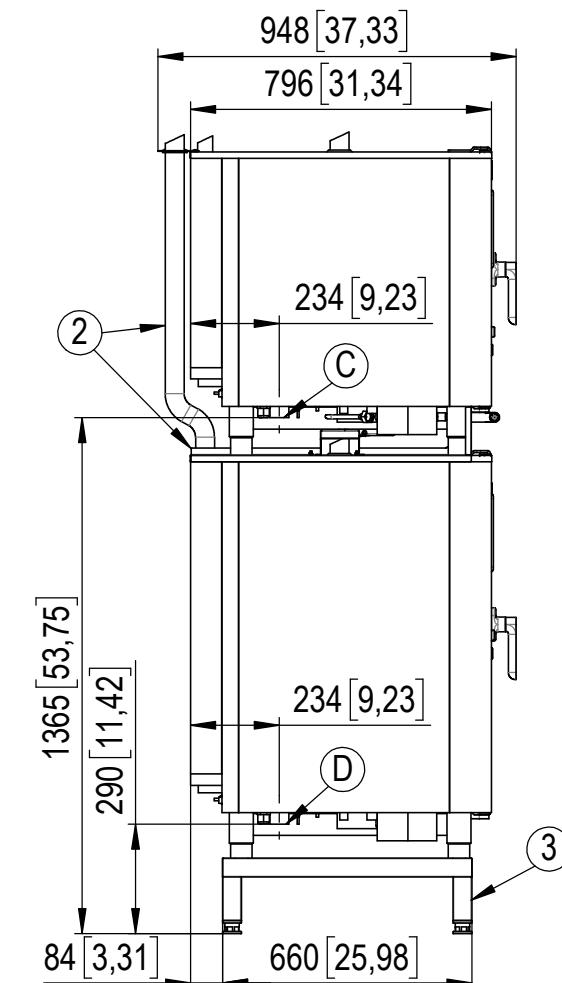
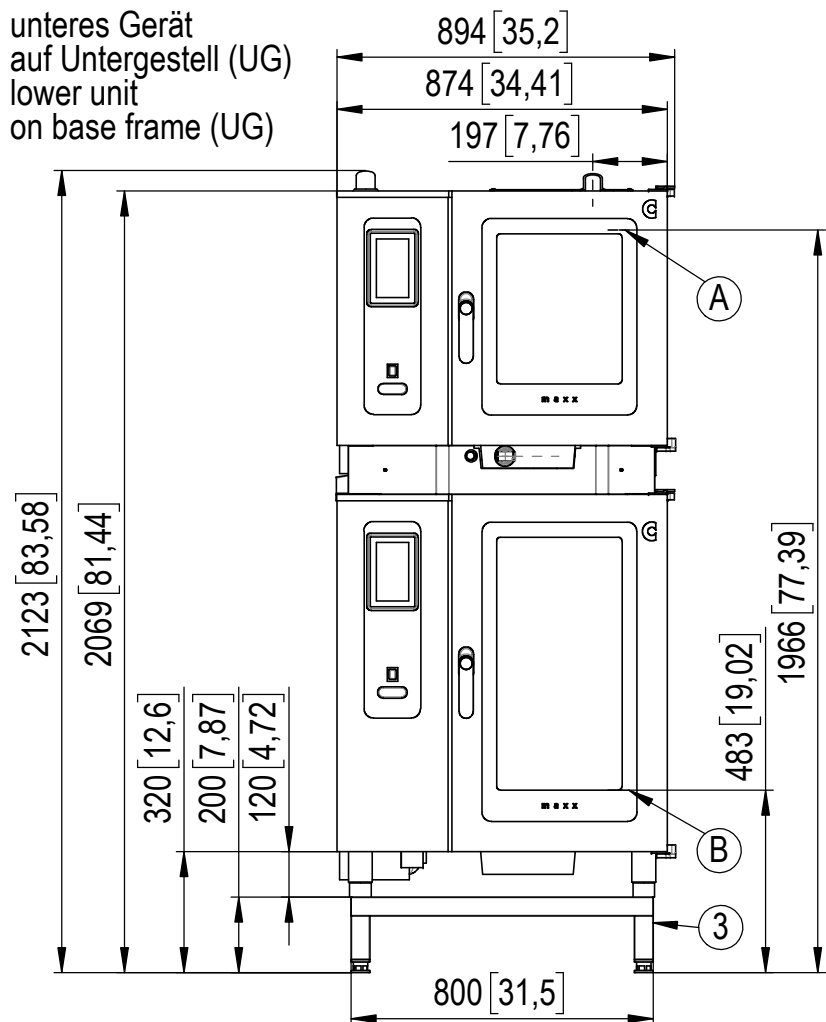

- A: Oberster Einschub/ Upper tray
- B: Tiefster Einschub/ Lower tray
- C: Mittelpunkt oberer Abwasseranschluss DN50/
Center of upper water drainage hole DN50
- D: Mittelpunkt unterer Abwasseranschluss DN50/
Center of lower water drainage hole DN50

Pos.	Teil / Part	Benennung / Description	STK Cmx 10.10 unten / down 6.10 oben / top mit / with Gerätefuß Standard Appl. Feet Standard	STK Cmx 10.10 unten / down 6.10 oben / top mit / with Gerätefuß H=230 Appl. Feet H=230	STK Cmx 10.10 unten / down 6.10 oben / top mit / with Untergestell Stand
1	6267629	Set Gerätefuß 2" 230mm CF	-	1	-
2	6267719	STK 1 3 unt 1 ob Basis kpl CF	1	1	1
3	6267720	UG 1 3 200mm für STK 13 unt 1 ob kpl CF	-	-	1

CONVOTHERM
Convotherm Elektrogeräte GmbH
Talstraße 35
82436 Egfling, Deutschland
Telefon: +49 (0)8847 67-0
Fax: +49 (0) 8847 414
© 2020

General Tolerance:
DIN ISO 2768 - vL

Rev	Remarks	Date	Name
00	Z-Freigabe	Oct 07, 20	hschweig

Date	Name
Drawn Jun 17, 20	aneumeie
Ckd. Oct 07, 20	
App. Oct 07, 20	hschweig

Material	Revision 00.	Version 9
Stock Size	Weight 6.91 kg	
Description	Scale 1:20	
	Size A3	
DRG.No.	Sheet 2 of 2	
	K6267690	
Repl. for	Filename	00054563

All dimensions in mm [inch]
Do not scale