

Convotherm maxx pro easyTouch

- 10.10
- 10+1 Shelves GN 1/1
- Electric
- Injection/Spritzer
- Disappearing door



Key features

- Natural Smart Climate™ (ACS+) cooking methods: Steam, Combi-steam, Convection
- Natural Smart Climate™ (ACS+) with extra functions:
 - Crisp&Tasty – 5 moisture-removal settings
 - BakePro – 5 levels of traditional baking
 - HumidityPro – 5 humidity settings
 - Controllable fan – 5 speed settings
- easyTouch 10" TFT HiRes glass touch display (capacitive)
- ConvoClean+ fully automatic cleaning system with eco, regular and express modes – with optional single-dose dispensing
- HygieniCare
- WiFi and Ethernet interface (LAN)
- USB port integrated in the control panel
- TriColor indicator ring – indicates the current operating status
- Steam generated by injecting water into the oven cavity
- LED lighting in the oven cavity
- Disappearing door with triple glazing: more space and greater safety at work (available optionally at an additional charge)

Standard features

- Cooking methods:
 - Steam (30-130°C) with guaranteed steam saturation
 - Combi-steam (30-250 °C) with automatic moisture control
 - Convection (30-250 °C) with optimized heat transfer
- Operation of easyTouch user interface:
 - 10" TFT HiRes glass touch display (capacitive)
 - Smooth-action, quick-reacting scrolling function
 - Natural Smart Climate™ (ACS+)
- Climate Management
 - Natural Smart Climate™ (ACS+), HumidityPro, Crisp&Tasty
- Quality Management
 - Airflow Management, BakePro, Multi-point core temperature probe, Preheat and cool down function
- Production Management
 - Automatic cooking with Press&Go with up to 399 profiles
 - Integrated cookbook with 7 different categories
 - TrayTimer – load management for different products at the same time (manual mode)
 - TrayView – load management for automatic cooking of different products using Press&Go
 - Favorites management
 - HACCP data storage
 - USB port
 - ecoCooking – energy-save function
 - LT cooking (low-temperature cooking) / Delta-T cooking
 - Cook&Hold – cook and hold in one process
 - Auto Start
 - Regenerate+ – flexible multi-mode rethermalization function with preselect

Standard features

- Cleaning Management:
 - ConvoClean+: Fully automatic cleaning system
 - Quick access to individually created and saved cleaning profiles
 - Cleaning Scheduler
 - FilterCare Interface
- HygieniCare:
 - Hygienic Steam Function
 - Hygienic Handles
 - SteamDisinfect
- Design:
 - Unit door with triple glazing, safety latch, sure-shut function, venting position and LEDs for oven cavity lighting
 - Steam generated by injecting water into the oven cavity
 - Adjustable appliance feet, from 100 mm to 125 mm
 - Multi-point core temperature probe
 - Integrated recoil hand shower

IPX5 **CE**

Convotherm maxx pro easyTouch

- 10.10
- 10+1 Shelves GN 1/1
- Electric
- Injection/Spritzer
- Disappearing door



Key features

- Natural Smart Climate™ (ACS+) cooking methods: Steam, Combi-steam, Convection
- Natural Smart Climate™ (ACS+) with extra functions:
 - Crisp&Tasty – 5 moisture-removal settings
 - BakePro – 5 levels of traditional baking
 - HumidityPro – 5 humidity settings
 - Controllable fan – 5 speed settings
- easyTouch 10" TFT HiRes glass touch display (capacitive)
- ConvoClean+ fully automatic cleaning system with eco, regular and express modes – with optional single-dose dispensing
- HygieniCare
- WiFi and Ethernet interface (LAN)
- USB port integrated in the control panel
- TriColor indicator ring – indicates the current operating status
- Steam generated by injecting water into the oven cavity
- LED lighting in the oven cavity
- Disappearing door with triple glazing: more space and greater safety at work (available optionally at an additional charge)

Options

- Quality Management: ConvoSmoke – built-in food-smoking function (HotSmoke)
- ConvoGrill with grease management function (on request)
- Steam and vapour removal – built-in condensation module (on request)
- Marine version (see separate datasheet)
- maxx pro BAKE (see separate datasheet)
- Prison version
- Available in various voltages
- Sous-vide probe, external connection
- Core temperature probe, external connection

Accessories

- Production Management: KitchenConnect® (WiFi/LAN), network solution from Welbilt for updating and monitoring appliances from anywhere
- ConvoVent 4 condensation hood with grease filter
- ConvoVent 4+ condensation hood with grease and odour filter
- Signal tower – external operating-state indicator
- Banquet system (optionally as a package or individually): Plate rack, mobile shelf rack, transport trolley, thermal cover
- Stands in various sizes and designs
- Racks, choice of GN or BM versions (BM = standard baking sheet size)
- Stacking kits
- Care products for the ConvoClean+ fully automatic cleaning system (multiple and single-measure dispensing)

Front view

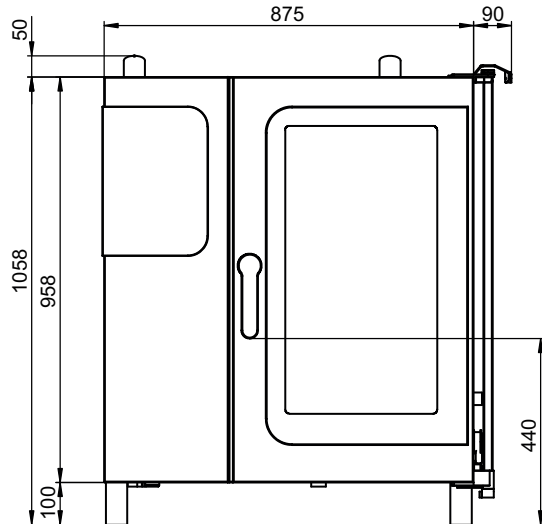

Connection points

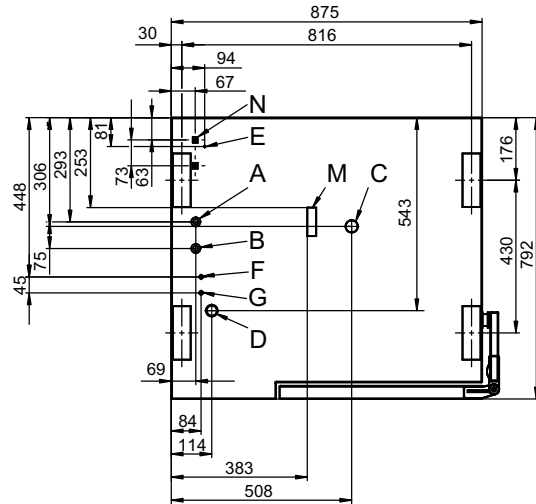

- A Water connection (for water injection)
- B Water connection (for cleaning, recoil hand shower)
- C Drain connection DN 50
- D Electrical connection
- E Equipotential bonding
- F Rinse-aid connection
- G Cleaning-agent connection
- H Air vent Ø 50 mm
- I Dry air intake Ø 50 mm
- M Safety overflow 80 x 25 mm
- N RJ45 Ethernet port

View from above with wall clearances

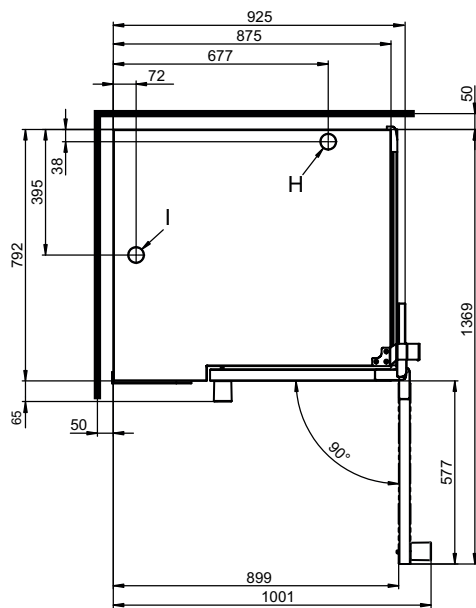

Dimensions and weights

Dimensions including packaging	
Width x Height x Depth	1100 x 1300 x 940 mm
Weight	
Empty weight without options* / accessories	130 kg
Weight of packaging	28 kg
Safety clearances**	
Rear	50 mm
Right-hand side (disappearing door pushed back)	130 mm
Left (see installation instructions)	50 mm
Top***	500 mm

Installation instructions

Clearance from heat sources	min. 500 mm
Recommended clearance for service, left side of unit	min. 500 mm

The combi oven must be set up with 3 sides free to provide access for cleaning. As an alternative, use a 150 mm high foot; on request.

* Weight of options 15 kg max.

** Required for functionality of appliance.

*** Depends on type of air ventilation system and nature of ceiling.

Loading capacity

Max. number of food containers	
GN 1/1*	10+1
600 x 400** baking tray	8
Plates max. Ø 32 cm, Ring spacing 65 mm**	32
Plates max. Ø 32 cm, Ring spacing 78 mm**	26
Maximum loading weight	
GN 1/1 / 600 x 400	
Per combi oven	50 kg
Per shelf level	15 kg

* Matching rack included as standard.

** Matching rack available as an accessory.

Electrical supply

3N~ 400V 50/60Hz*	
Rated power consumption	19.5 kW
Rated power consumption with Smoker	19.8 kW
Rated current	28.1 A
Fuse rating	32 A
RCD (GFCI), single-phase frequency converter	Type A/B
Recommended conductor cross-section	5G6
3N~ 380V 60Hz	
Rated power consumption	17.6 kW
Rated current	26.7 A
Fuse rating	32 A
RCD (GFCI), single-phase frequency converter	A/B
Recommended conductor cross-section	5G6
3~ 230V 50/60Hz*	
Rated power consumption	19.3 kW
Rated current	48.5 A
Fuse rating	50 A
RCD (GFCI), single-phase frequency converter	Type A/B
Recommended conductor cross-section	4G16
3~ 200V 50/60Hz*	
Rated power consumption	19.3 kW
Rated current	55.8 A
Fuse rating	63 A
RCD (GFCI), single-phase frequency converter	Type A/B
Recommended conductor cross-section	4G16
3~ 400V 50/60Hz*	
Rated power consumption	19.5 kW
Rated current	28.1 A
Fuse rating	35 A
RCD (GFCI), three-phase frequency converter	Type B
Recommended conductor cross-section	5G6

* Connection to energy optimization system included as standard.

PLEASE NOTE: If the ConvoSmoke option is chosen, the only voltages available are 3~ 230V 50/60Hz and 3N~ 400V 50/60Hz.

Water connection

Water supply	
Water supply	2 x G 3/4" fixed connection, optionally including connecting pipe (min. DN13 / 1/2")
Flow pressure	150 - 600 kPa (1.5 - 6 bar)
Appliance drain	
Drain version	Funnel drain with P-trap (recommended) or fixed connection
Type	DN 50 (min. internal Ø: 46 mm)
Slope for drain pipe	min. 3.5% (2°)

Water quality

Water-supply connection A* for water injection	
General requirements	Drinking water, typically soft water (install water treatment system if necessary)
General hardness	4 - 7 °dh / 70 - 125 ppm / 7 - 13 °TH / 5 - 9 °e
Water-supply connection B* for cleaning, recoil hand shower	
General requirements	Drinking water, typically hard water
General hardness	4 - 20 °dh / 70 - 360 ppm / 7 - 35 °TH / 5 - 25 °e
Water-supply connections A, B*	
pH value	6.5 - 8.5
Cl ⁻ (chloride)	max. 60 mg/l
Cl ₂ (free chlorine)	max. 0.2 mg/l
SO ₄ ²⁻ (sulphate)	max. 150 mg/l
Fe (iron)	max. 0.1 mg/l
SiO ₂ (silicate)	max. 13 mg/l
NH ₂ Cl (monochloramine)	max. 0.2 mg/l
Temperature	max. 40 °C
Electrical conductivity	min. 20 µS/cm

* See diagram of connection points, page 2.

Water consumption

Water-supply connection A*	
Ø Consumption for cooking	4.2 l/h
Max. consumption	0.6 l/min
Water-supply connections A, B	
Ø Consumption for cooking**	6.3 l/h
Max. water flow rate	15 l/min

* Values for selecting the capacity of the water treatment system.

** Including water used for cooling the wastewater.

PLEASE NOTE: See diagram of connection points, page 2.

Emissions

Dissipated heat*	
Latent heat	2900 kJ/h / 0.81 kW
Sensible heat	3600 kJ/h / 1.00 kW
Waste water temperature	max. 80 °C
Noise during operation	max. 70 dBA

* The dissipated heat values were measured as per DIN 18873-1 "Methods for measuring the energy use of equipment for commercial kitchens — Part 1". The type and frequency of appliance usage are decisive for the specification of an air conditioning and ventilation system. These values can be higher than the values indicated for dissipated heat. Guide values can be found in the technical literature, e.g. in VDI 2052. Please consult your specialized design engineer for planning an air conditioning and ventilation system.

ACCESSORIES

(Please refer to the Accessories brochure for detailed information)

Stacking kit

Permitted combination	6.10 on 10.10
For a combination of two electric appliances	
Select "Stacking kit for Convotherm 4 electric appliances"	
For a combination of one electric appliance and one gas appliance in the stacking kit	
Select "Stacking kit for Convotherm 4 electric appliances" if:	
Bottom combi oven	EB/ES
Top combi oven	GB/GS
Select "Stacking kit for Convotherm 4 gas appliances" if:	
Bottom combi oven	GB/GS
Top combi oven	EB/ES

ACCESSORIES

Condensation hood ConvoVent 4*

Electrical supply	
Rated voltage	1N~ 200-240V 50/60Hz
Rated power consumption	130-260 W
Rated current	1.0-1.9 A
Fuse rating	2.5 A
Dimensions excluding packaging	
Width x Height x Depth	877 x 240 x 1085 mm
Weight excluding packaging	66 kg
Safety clearance above**	500 mm

* Condensation hoods specially designed for stacking kits are available.

** Depends on type of air ventilation system and nature of ceiling.

Condensation hood ConvoVent 4+*

Electrical supply	
Rated voltage	1N~ 200-240V 50/60Hz
Rated power consumption	130-260 W
Rated current	1.0-1.9 A
Fuse rating	2.5 A
Dimensions excluding packaging	
Width x Height x Depth	877 x 373 x 1085 mm
Weight excluding packaging	85 kg
Safety clearance above**	500 mm

* Condensation hoods specially designed for stacking kits are available.

** Depends on type of air ventilation system and nature of ceiling.

Please observe the following points:

- This document is to be used solely for planning purposes.
- Please refer to the Installation manual for further technical data and guidance on installation and positioning.

9769326_02_ENG_GBR 07/23, © 2023 Welbilt. Continuous improvements to the product may mean changes to the specification are made without explicit mention.